

PAUL SCHERRER INSTITUT

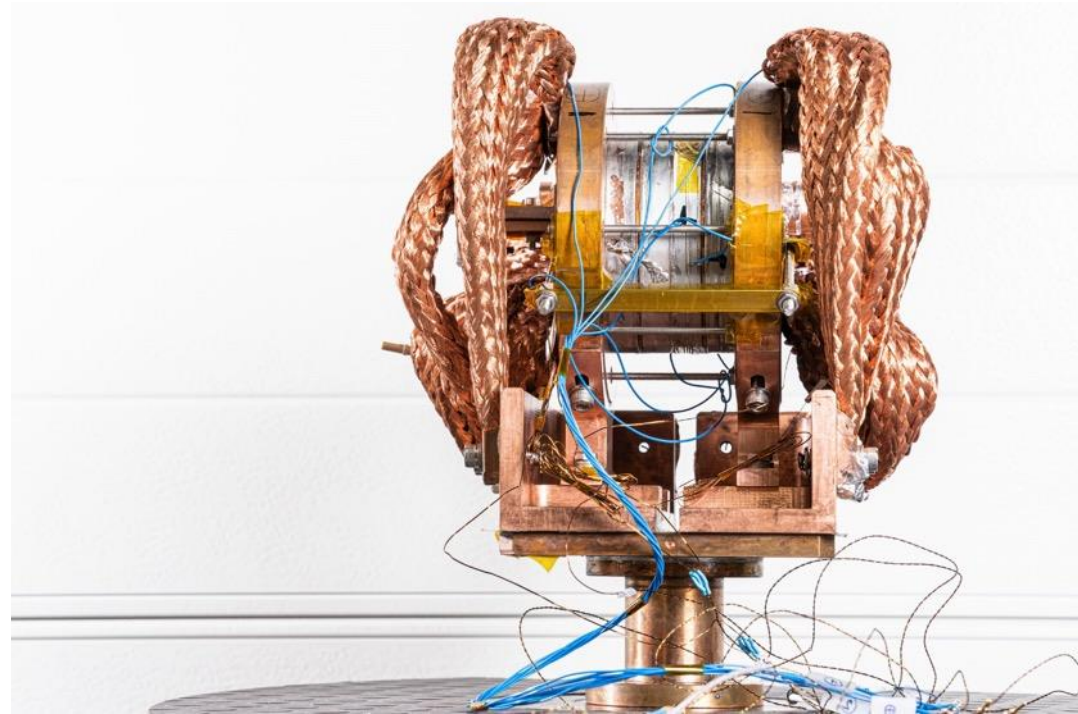

26.10.2023 – PSI Theory Colloquium

Magnet R&D for the FCC and the CHART MagDev Activity

D. M. Araujo, B. Auchmann, A. Brem, M. Daly, M. Duda, O. Kirby, M. Koratzinos, J. Kosse, T. Michlmayr, C. Müller, H. G. Rodrigues, S. Sanfilippo, D. Sotnikov

MuCol slides by L. Bottura for the Muon Magnets Working Group

This work was performed under the auspices of and with support from the Swiss Accelerator Research and Technology (CHART) program (www.chart.ch).

- CHART and MagDev and the HFM Program
- FCC-hh
 - LTS accelerator magnets
 - Main challenges
 - MagDev LTS technology program
 - HTS accelerator magnets
 - the promise
 - the difficulties
 - MagDev HTS technology program
- FCC-ee
 - Technology coils and P3 experiment
 - HTS4
 - MDI
- Muon Collider magnets
- Synergies
 - Neutron scattering
 - RICS proposal
 - Muon target study

CHART Applied Superconductivity

- “CHART, the Swiss Center for Accelerator Research and Technology, was founded to support the future oriented accelerator project Future Circular Collider (FCC) at CERN and the development of **advanced accelerator concepts in Switzerland beyond the existing technology**. [...] The high field magnet R&D has strong synergies with PSI projects [...]”
[Application for support of the Swiss Accelerator Research and Technology Initiative, 2018]
- ~50% of the effort directed to Applied Superconductivity for accelerators.

PSI:
MagDev
FCCee HTS4

ETHZ:
MagRes
MagComp
MagNum
MagAM
FCCee CPES

UniGE
WireDev
WireChar

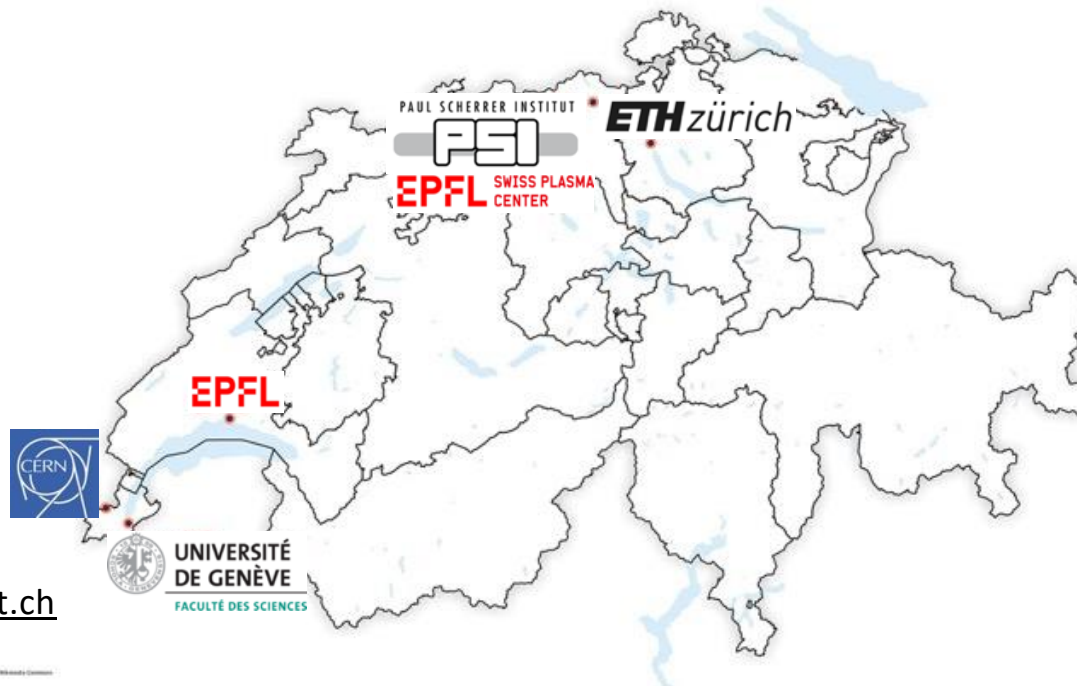

<http://chart.ch>

Vision of the HFM Programme

Create an innovative HFM research network that enables a future flagship HEP project in Europe.

- Fast-track pressing technology R&D.
- Invest in paradigm-shifting technologies.
- Provide timely feedback to ESPP via technology demonstrations and credible roadmaps.

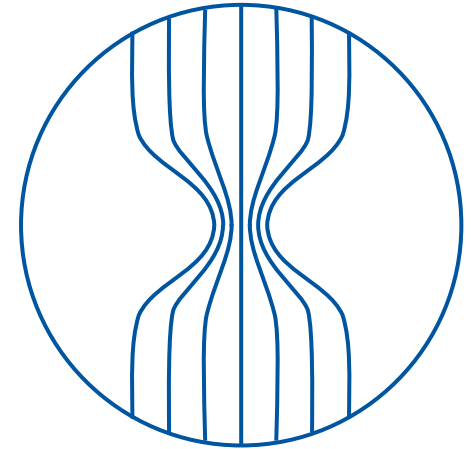

HFM
High Field Magnets

<https://cern.ch/hfm>

1. Demonstrate Nb₃Sn magnet technology for large scale deployment, pushing it to its limits in terms of maximum field and production scale.
 - The effort to quantify and demonstrate Nb₃Sn ultimate field comprises the development of conductor and magnet technology towards the ultimate Nb₃Sn performance.
 - Develop Nb₃Sn magnet technology for collider-scale production, through robust design, industrial manufacturing and cost reduction.
2. Demonstrate the suitability of HTS for accelerator magnets, providing a proof-of-principle of HTS magnet technology beyond the reach of Nb₃Sn.

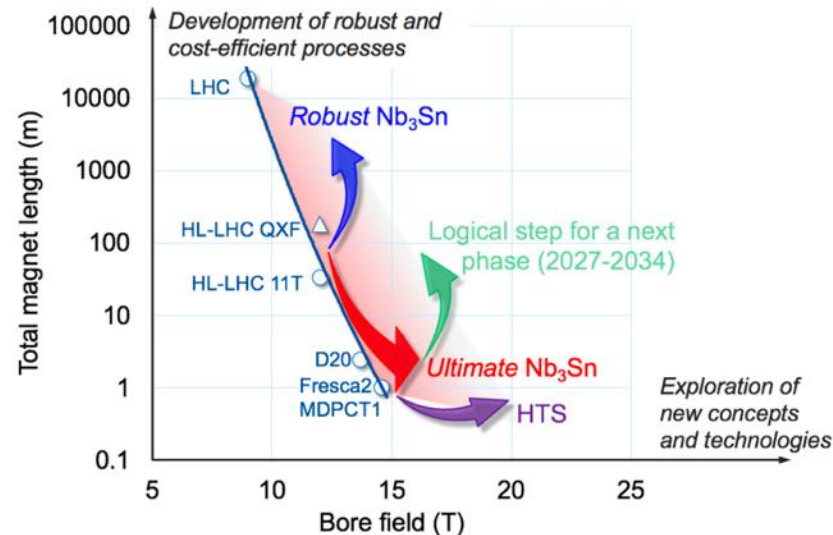

Magnets



Conductors



Enabling Technologies



Governance

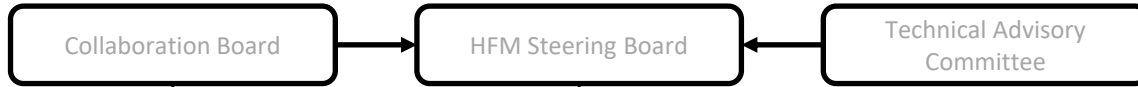

Executive

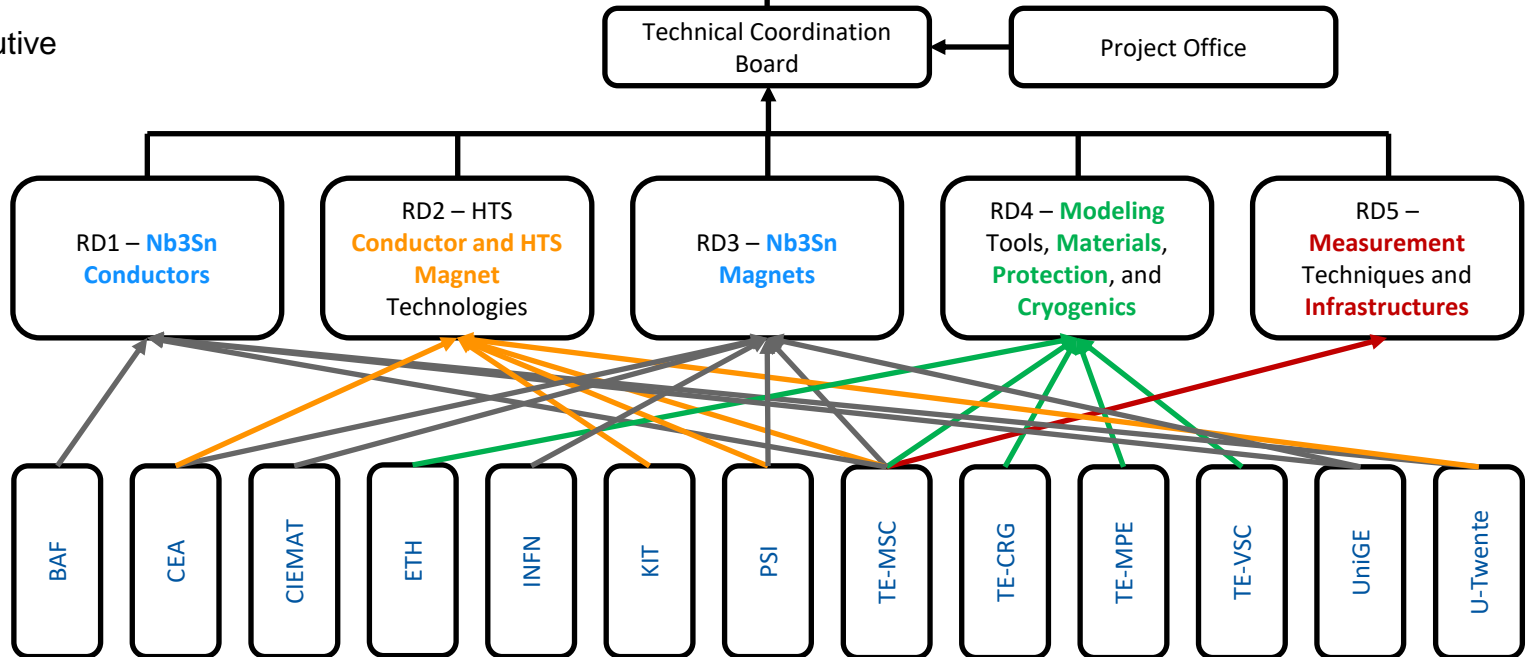

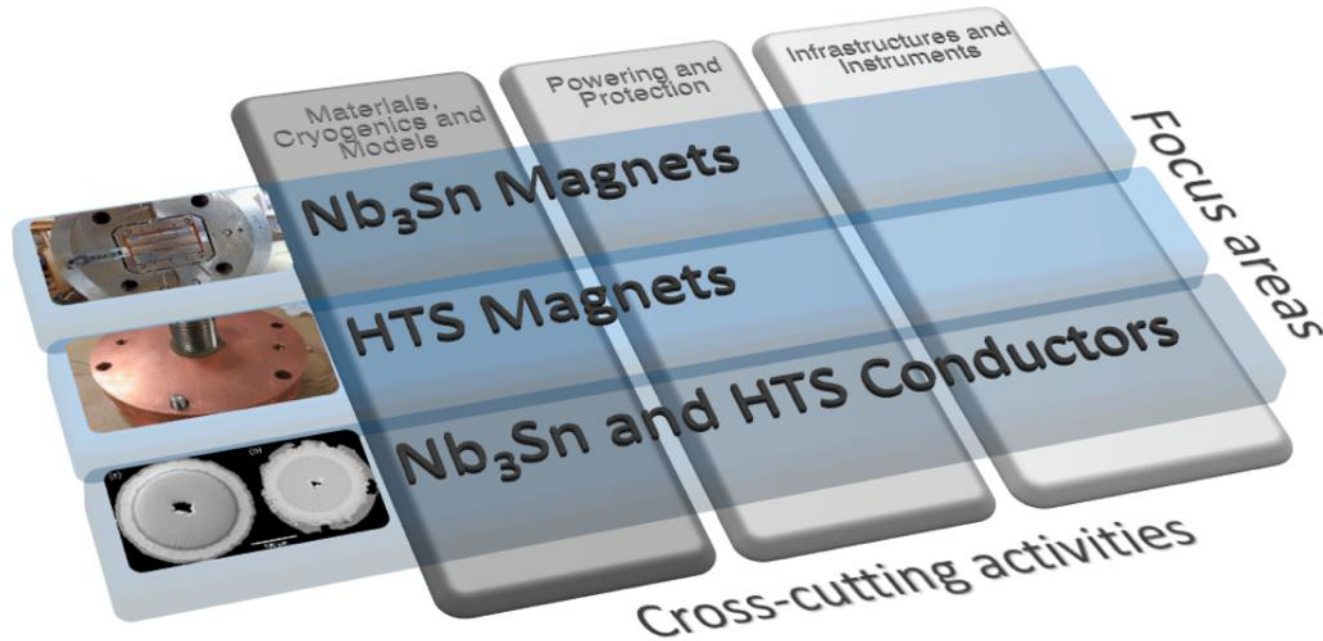

“The R&D programme must be holistic in nature: a compatible selection of electromagnetic, mechanical and thermal design approaches, conductors, materials, and manufacturing processes needs to be integrated seamlessly with instrumentation and protection into a magnet solution responding to the required specification.”
Conversely, work across R&D lines must be closely integrated.

- CHART and MagDev and the HFM Program
- FCC-hh
 - LTS accelerator magnets
 - Main challenges
 - MagDev LTS technology program
 - HTS accelerator magnets
 - the promise
 - the difficulties
 - MagDev HTS technology program
- FCC-ee
 - Technology coils and P3 experiment
 - HTS4
 - MDI
- Muon Collider magnets
- Synergies
 - Neutron scattering
 - RICS proposal
 - Muon target study

Nb-Ti Accelerator Magnets

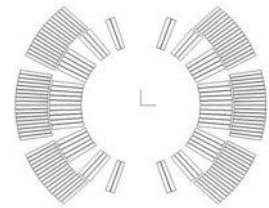
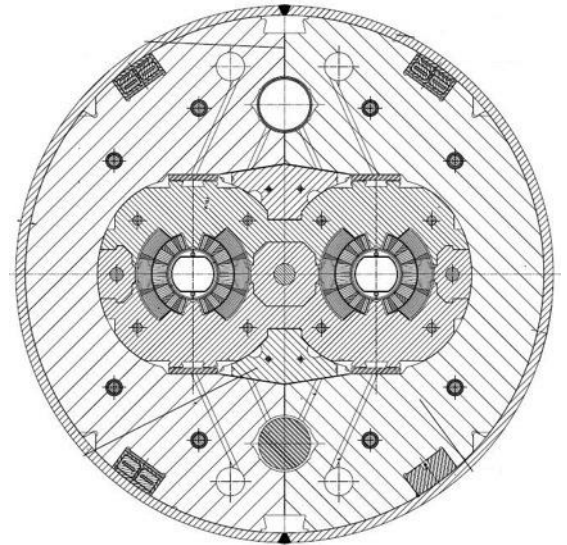
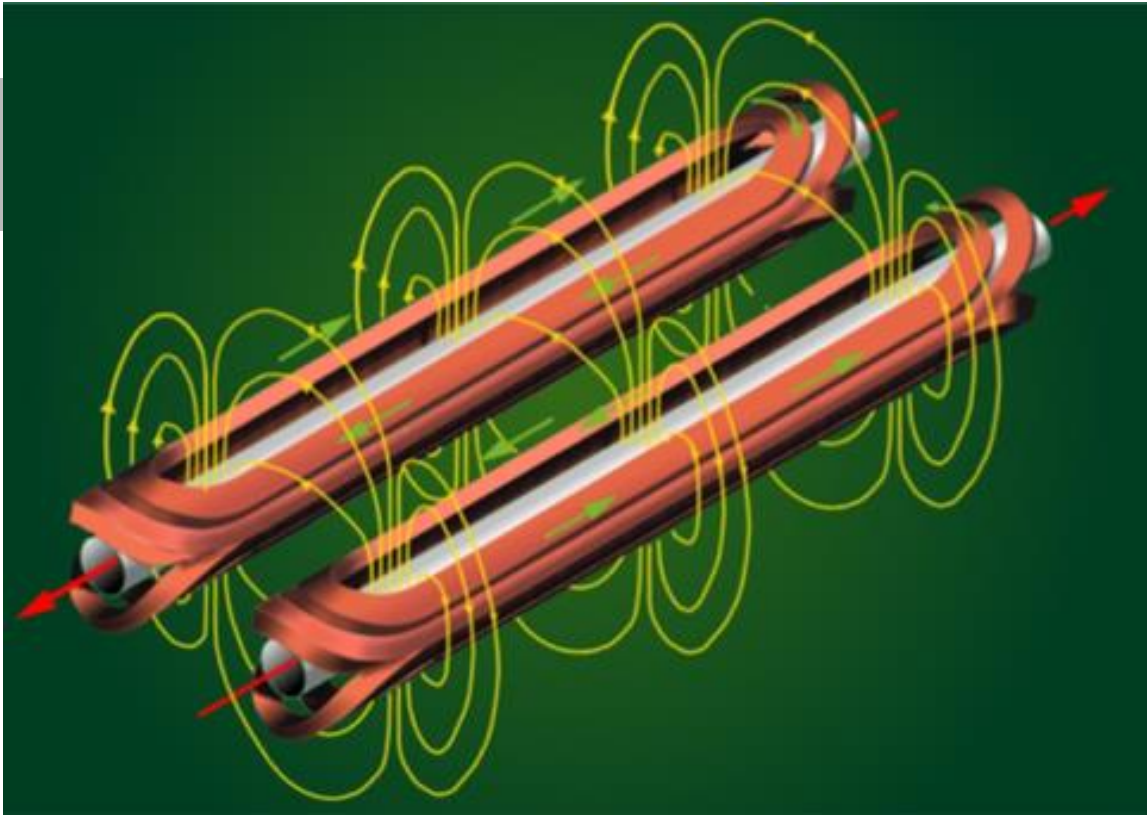

Tevatron

HERA

RHIC

LHC

76 mm bore
 $B = 4.4 \text{ T}$
 $T = 4.2 \text{ K}$
 first beam 1983

75 mm bore
 $B = 5.0 \text{ T}$
 $T = 4.5 \text{ K}$
 first beam 1991

80 mm bore
 $B = 3.5 \text{ T}$
 $T = 4.3\text{-}4.6 \text{ K}$
 first beam 2000

56 mm bore
 $B = 8.34 \text{ T}$
 $T = 1.9 \text{ K}$
 first beam 2008

Nb-Ti Technology Stack

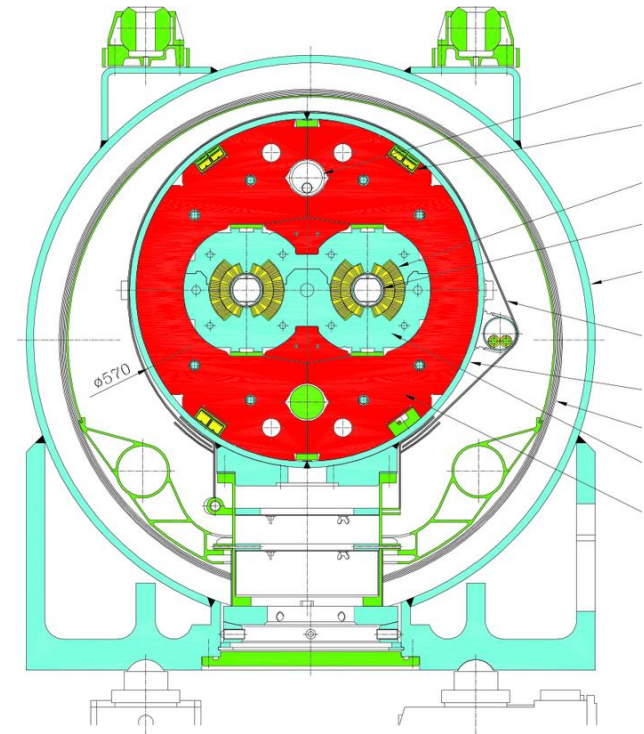
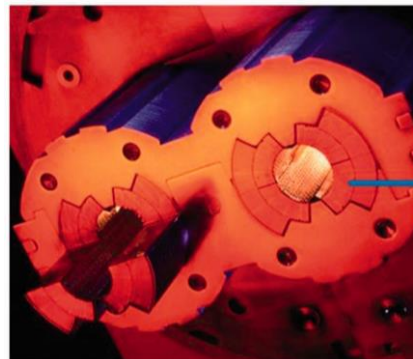
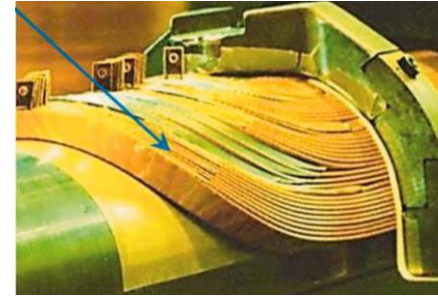
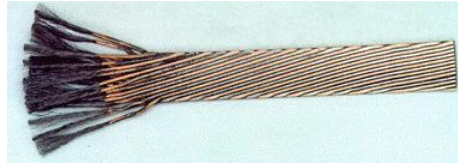

- Filameted twisted wires
- Rutherford cable
- Kapton-wrap insulation
- Cos-theta coil geometry
- Full pre-stress (collars)
- Hel or Hell bath with heat exchanger

Early Era of Nb₃Sn

CERN with ELIN (AT)

Design field 10 T.

1989 reached 9.5 T at 4.3 K.

Technology was judged too immature to pursue for LHC.

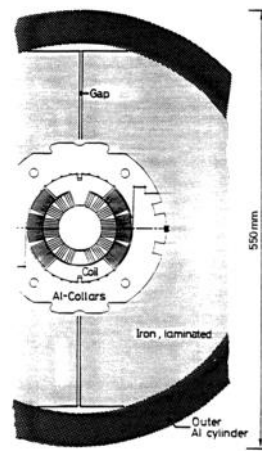

Fig.1: Schematic cross-section of the 1m long full aperture dipole magnet

Twente, NE

1995 MSUT magnet reached 11.3 T.

Issues with conductor (filament size, cable eddy current).

First accelerator magnet above 10 T

Very little training.

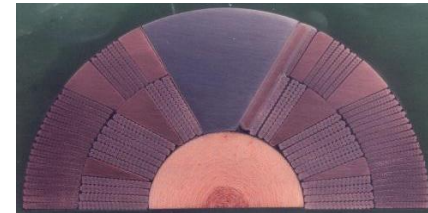
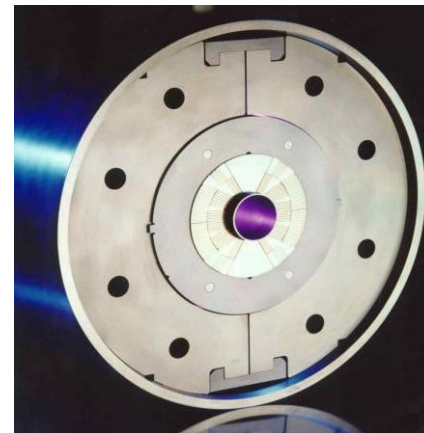

Nb₃Sn Cable Technology

- The superconducting A15 phase is brittle and strain sensitive. Niobium and Tin are, therefore, co-extruded in the Rod-Restack Process into a strand.
- In wind-and-react processes, several 10s of strands form a Rutherford cable, that is insulated and used to wind a coil.
- The A15 phase is created during a heat treatment of 180 h at up to 660°C.

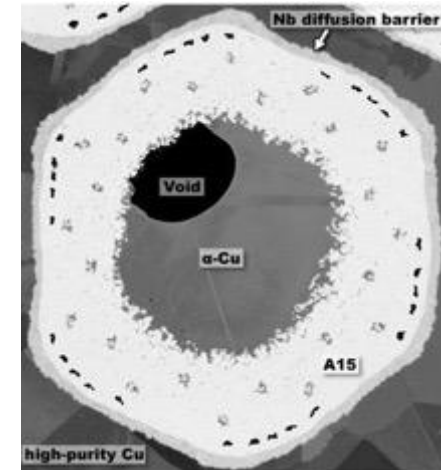
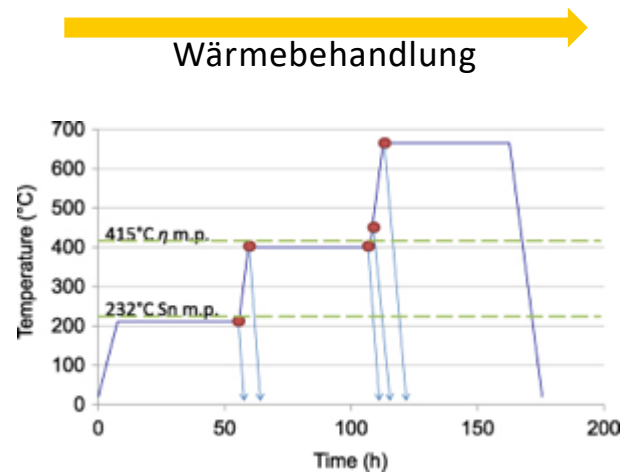
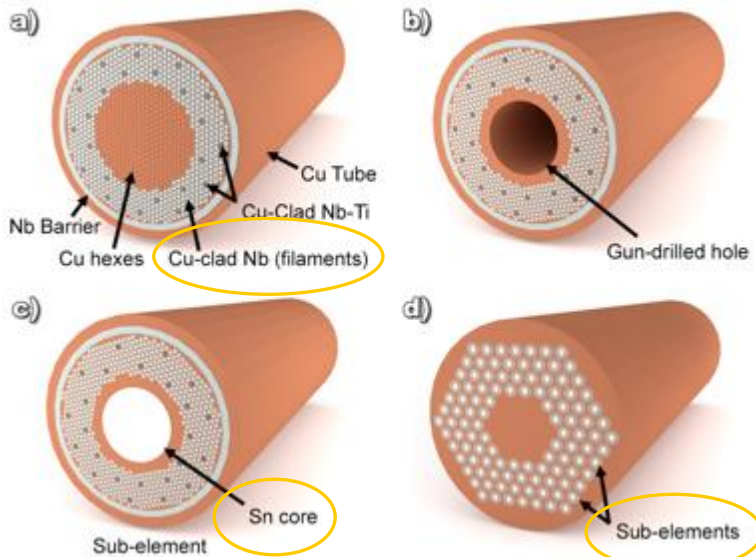
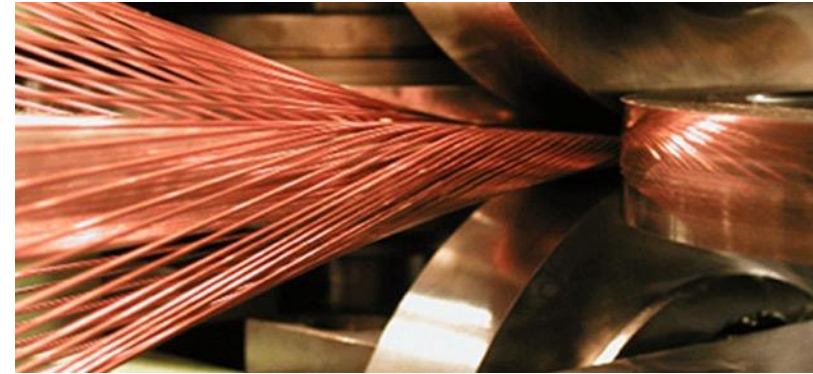

Subelement mit A15 Phase

Nb₃Sn Technology Stack

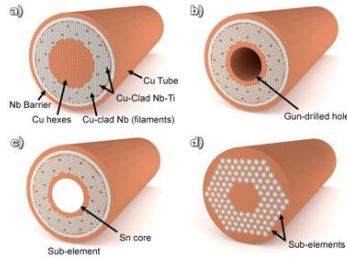

Rod-Restack Process twisted wires.
 Rutherford cable
 S2 glass braid insulation
 Cos-theta winding
 Reaction
 Epoxy Impregnation
 Bladder&Key loading
 HeI or HeII bath with heat exchanger

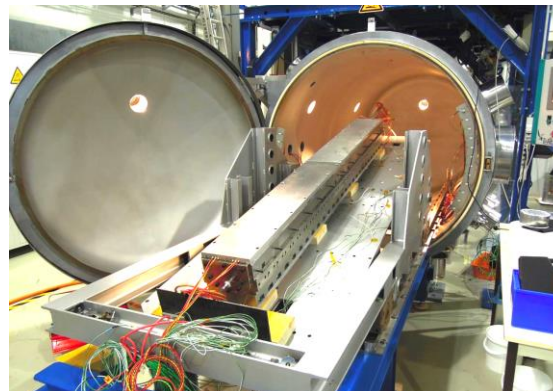

Full Pre-Stress Paradigm

- A lesson learned from the Nb-Ti era.
- Keep coils under compression at all stages of operation
 - avoid stick-slip motion.
 - Forces scale quadratically with field. For 16 T dipole, forces equivalent of 1.5 kt/m pull coil-halves apart.
 - 10 μm abrupt movement is enough to cause quench.
- However, need to limit stress on Nb₃Sn to 150-200 MPa.
- Axial forces and CTE mismatch are another major challenge.

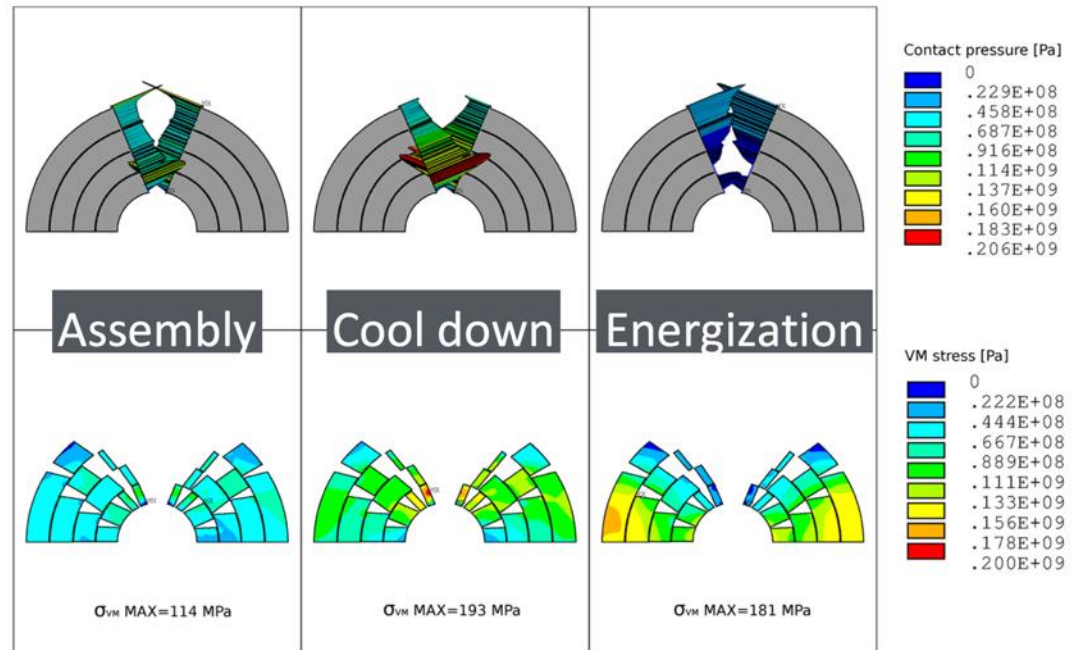
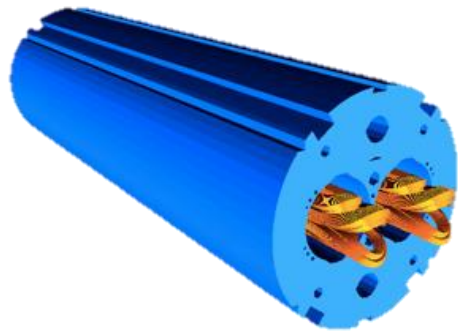
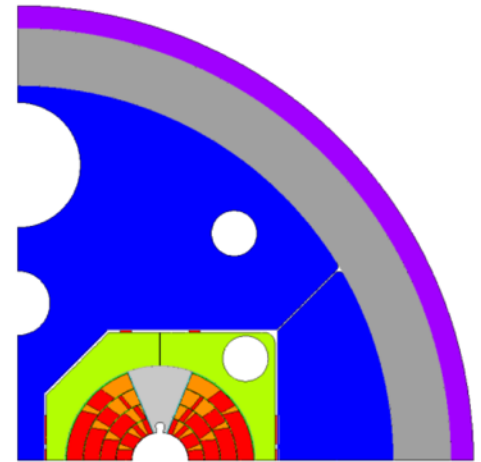

Cosine Theta Coil

Highest efficiency. Difficult stress management and coil end design.

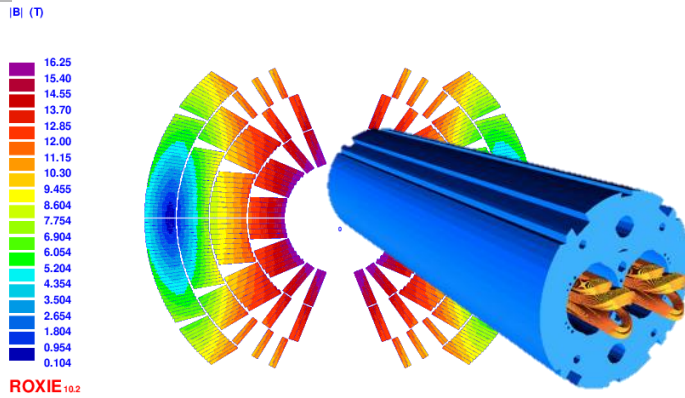

Block Coil

On paper simpler end design.
Slightly lower efficiency.

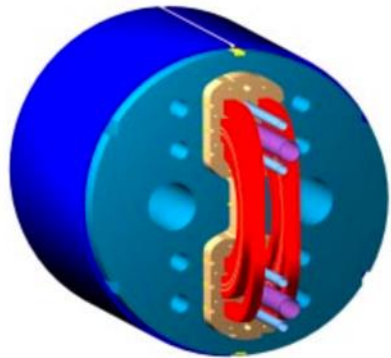
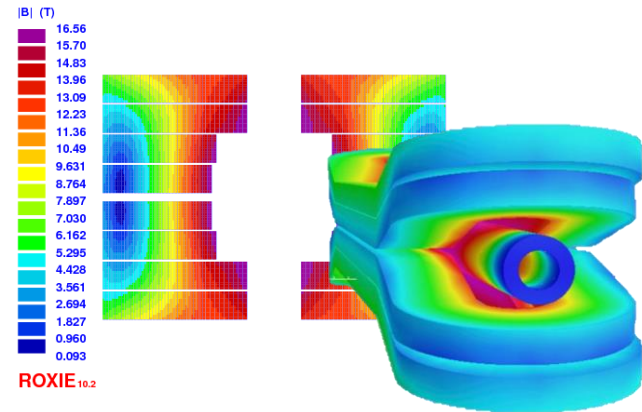

Common Coil

Simple coil ends.
Higher stored energy.
Slightly lower efficiency.

Canted Cosine Theta (Tilted Helices)

Simple manufacturing, low coil stress.
Reduced efficiency.

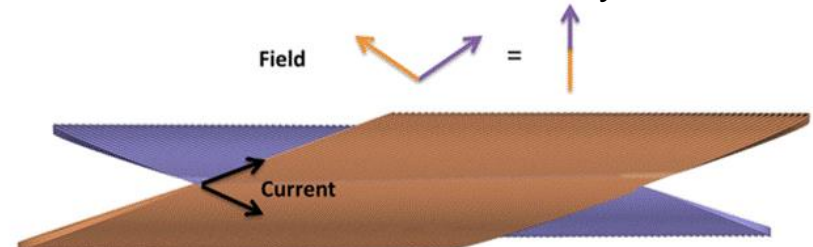

Stress Management Paradigm

- For stress-managed coils, the winding mandrel acts as an endo-skeleton, intercepting forces, conferring rigid support, and protecting the conductor.
- Stress-managed coils see (nearly) no stress before powering.
- The mandrel acts as winding, reaction, and impregnation tooing.
- CCT is the extreme case with force interception at every single turn.

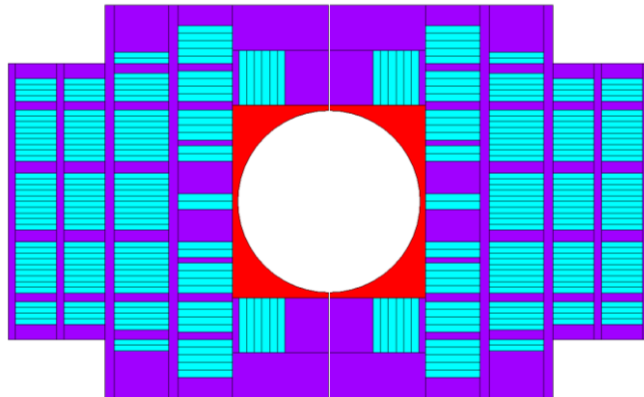

[Stress-managed common-coil concept, D. Araujo]

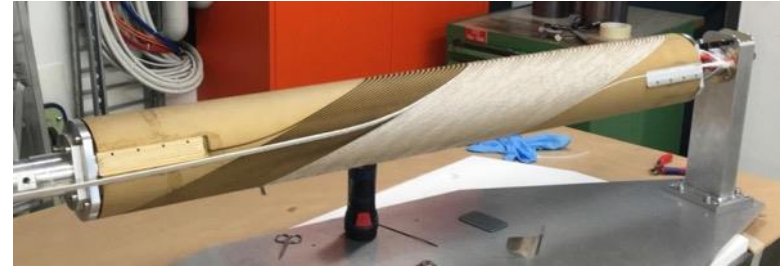

[CCT winding, G. Montenero]

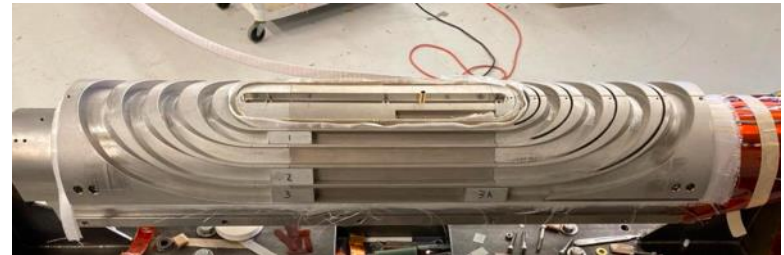

[SMCT winding; courtesy of A. Zlobin and I. Novitski, FNAL]

CHART CCT in EuroCirCol (2015-2019)

- CHART joined the Nb3Sn HFM R&D during the Horizon2020 EuroCirCol effort.
- PSI studied the Canted Cosine Theta option.

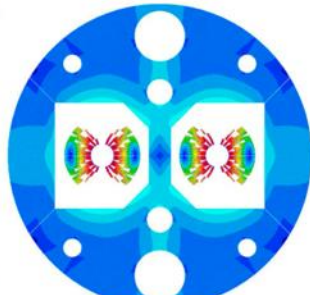
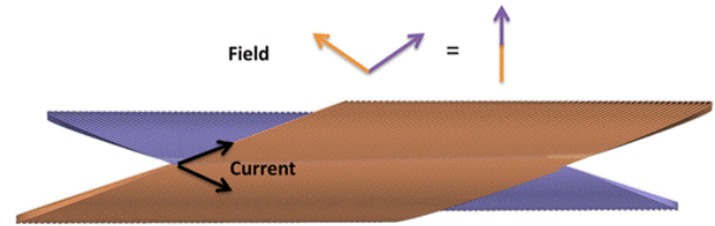

Cosine-theta

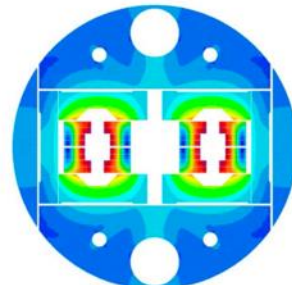

Block-coils

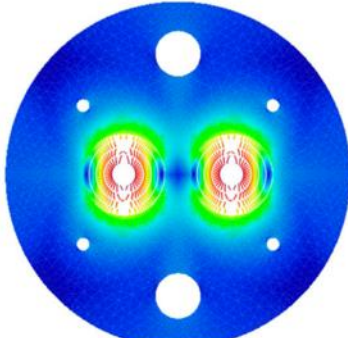

Canted cosine-theta

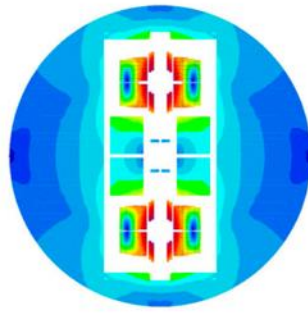

Common-coils

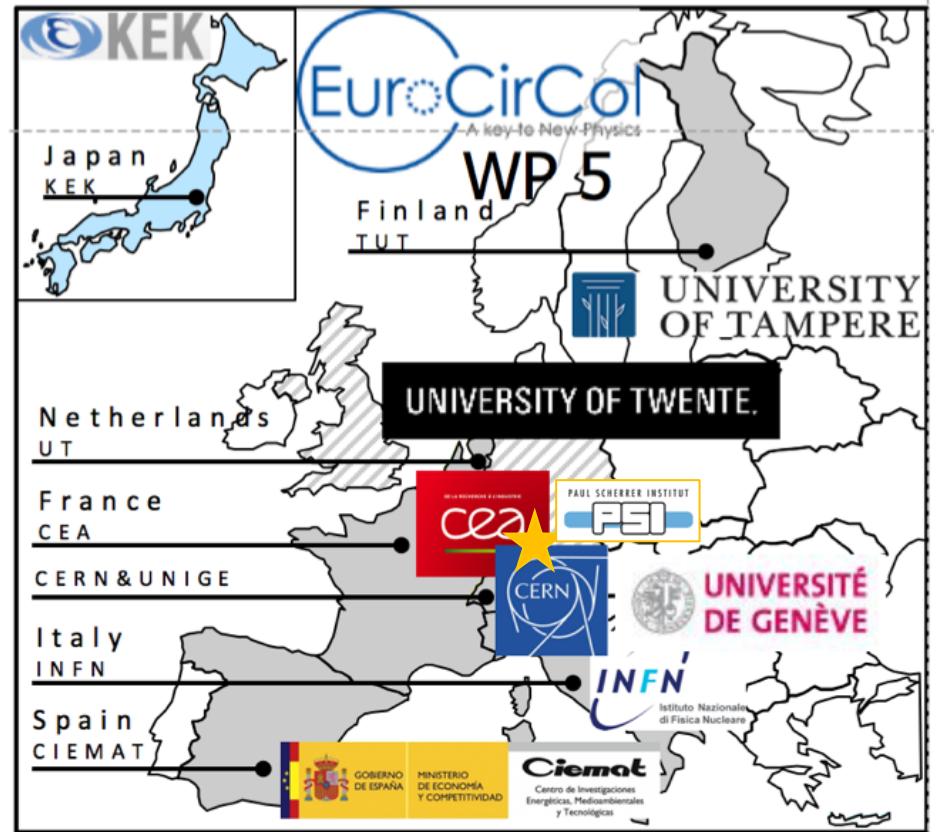
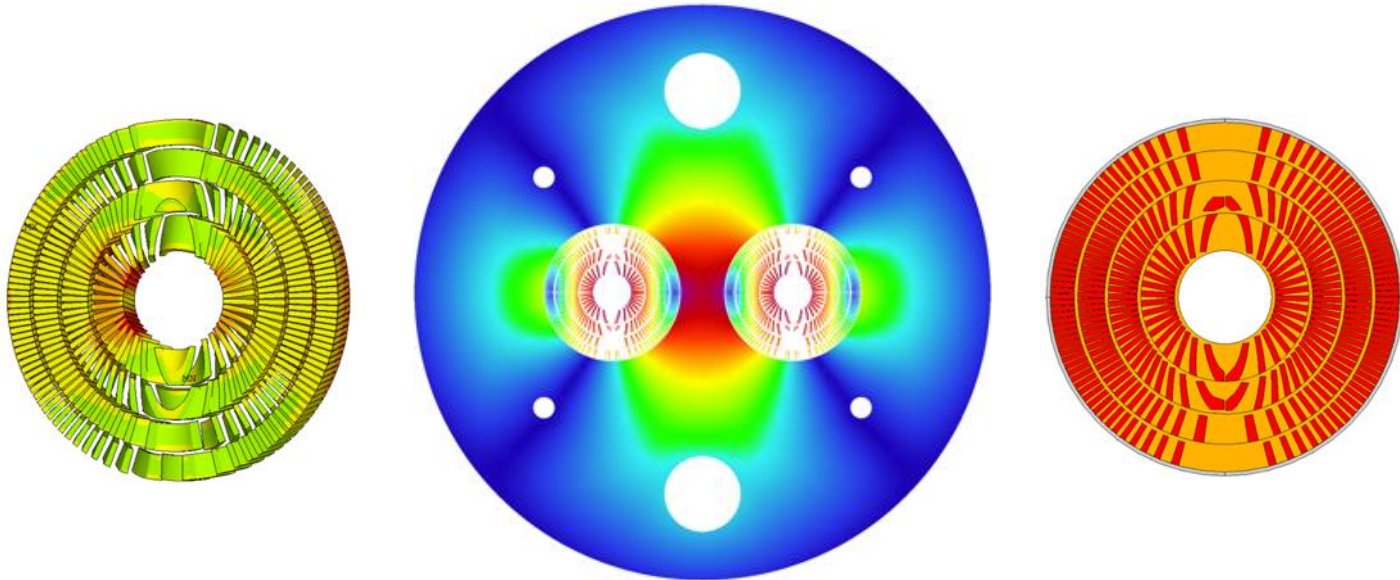

CHART CCT in the FCC-hh CDR

- EuroCirCol Design Goal: Shared specs and *minimization of conductor volume*.
- Stress Management adds mechanical margins and dilutes current density.
- CCT has 1/3 lower conductor stress (135 MPa) for 20% more conductor vol.



[B. Auchmann et al., *Electromechanical Design of a 16-T CCT Twin-Aperture Dipole for FCC*, IEEE Trans. on Appl. SC 28 (April, 2018) no. 3.]

[M. Benedikt et al., *FCC Conceptual Design Report*, Vol. 3 – The Hadron Collider (FCC-hh), pp. 50-52.]

Canted Dipole 1 built at PSI

- Magnet design, lab refurbishment, equipment, and commissioning, as well as magnet construction from 02.2017 to 10.2019.



Canted Dipole 1 built at PSI

- Magnet design, lab refurbishment, equipment, and commissioning, as well as magnet construction from 02.2017 to 10.2019.



[G. Montenero et al., *Coil Manufacturing Process of the First 1-m-Long Canted-Cosine-Theta (CCT) Model Magnet at PSI*, IEEE Trans. on App. SC., Vol 29(5), 2019.
G. Montenero et al., *Mechanical Structure for the PSI Canted-Cosine-Theta (CCT) Magnet Program*, IEEE Trans. on Appl. SC., Vol 28(3), 2018.]

CD1 Robustness and Performance

- CD1 main test was carried out in 2022/23.
- **It trained A LOT.**
- It reached **10.1 T in the bore** at 94% of I_{ss} at 1.9 K; 9.9 T and 100% of I_{ss} at 4.5 K.
- **But, it reached 100% of maximum field at 4.5 K.**
- These were the very first Nb₃Sn training coils at PSI:
 - No conductor degradation occurred from handling, assembly, powering, or thermal cycling.
- **Stress-management works, CD1 is a robust magnet.**



PSI CCT CD1 quenches

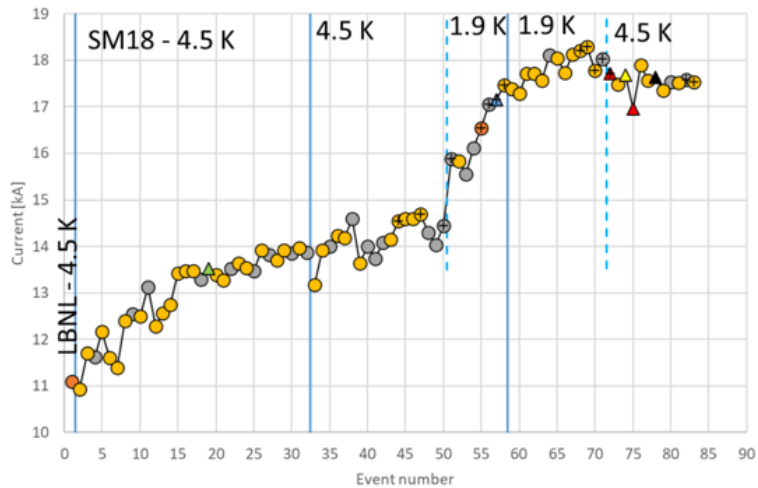

PSI CCT CD1 quenches

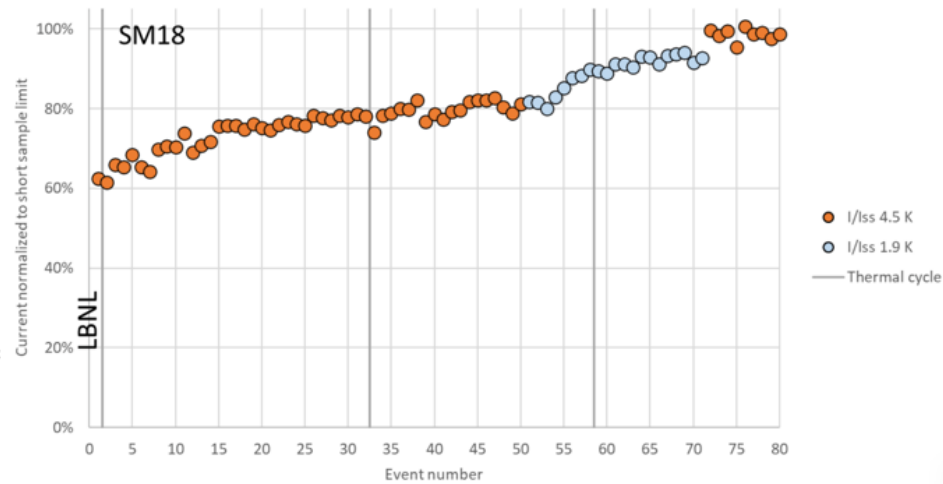

Courtesy F. Mangiarotti (CERN) and M. Daly (PSI).

Nb₃Sn Dipoles History

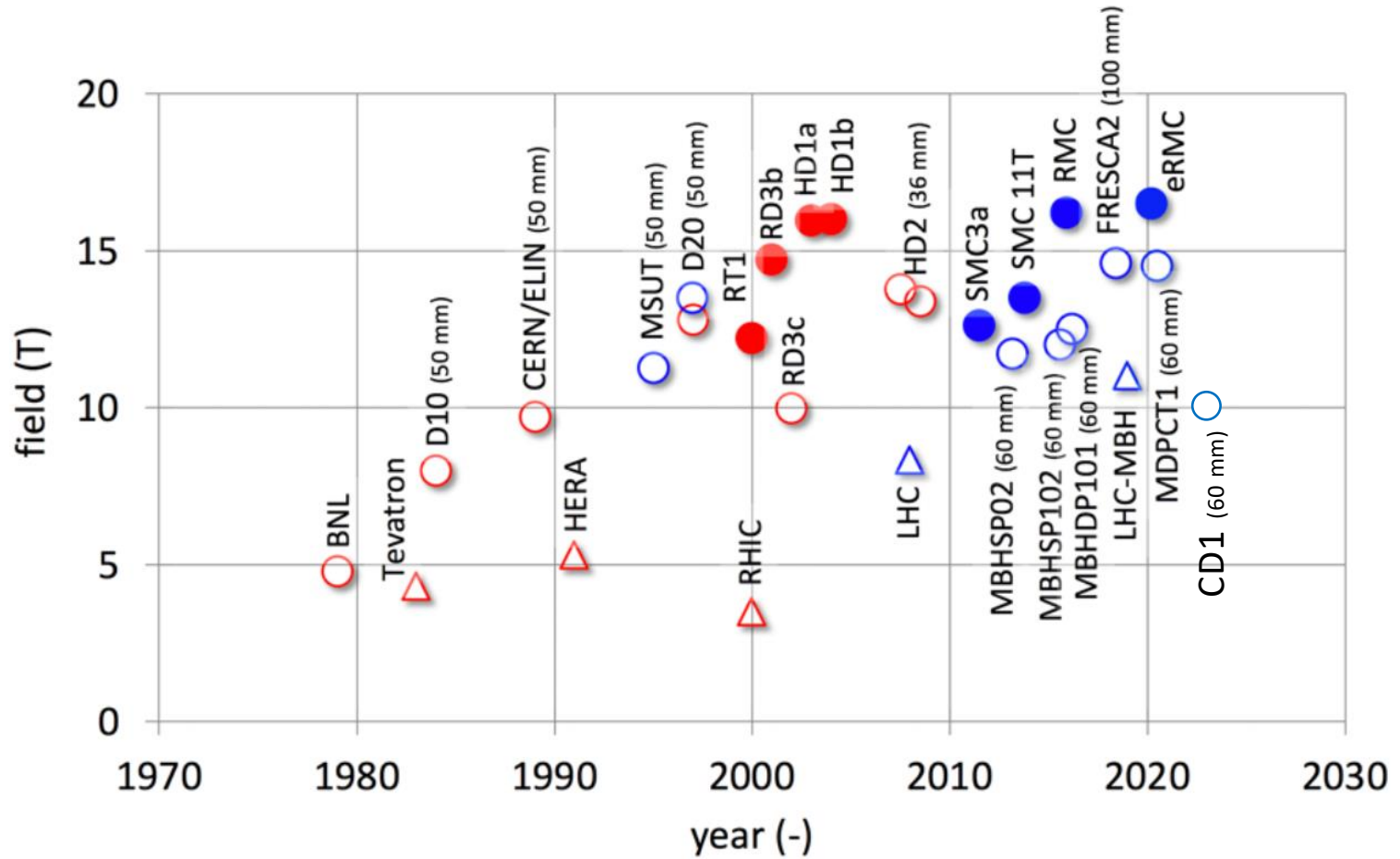

Courtesy L. Bottura

Fast-Turnaround Stress-Management R&D

- HFM R&D has suffered from slow turnaround and late feedback on technology.
- “We propose [...] a **succession of meaningful fast-turnaround demonstrations** [...]. In this way, **new technologies can be tested under realistic conditions at the earliest possible stage, the smallest relevant scale** and cost, and the fastest pace.”

[LDG Roadmap for High-Field Magnets. <https://arxiv.org/abs/2201.07895>]



ETH zürich

First deliverable

2019

2020

2024

2025/26

2PoM01-01,
D. Araujo

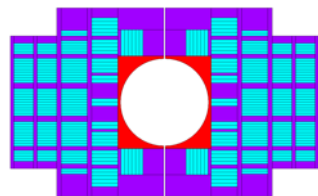

Courtesy D. Araujo

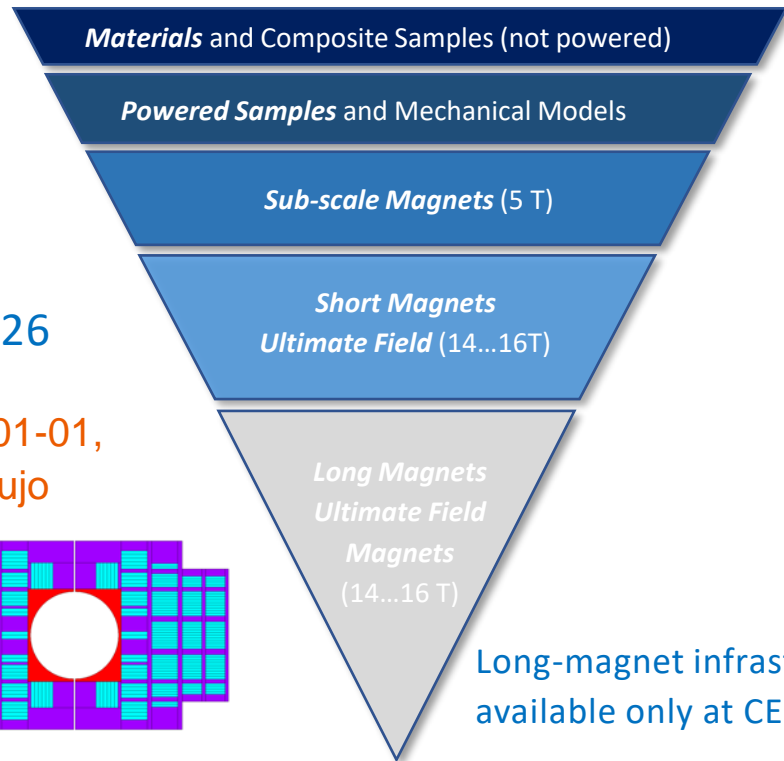

#Deliverables / year

100s

10

2-3

0.5-1

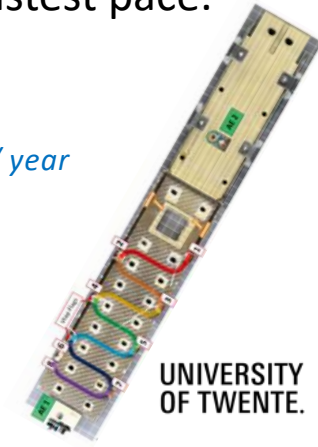

UNIVERSITY OF TWENTE.

Courtesy M. Daly

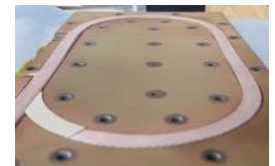

Courtesy D. Araujo
Brookhaven National Laboratory

Long-magnet infrastructure available only at CERN.



Douglas Araujo
Engineer LTS



Jaap Kosse
Engineer ReBCO



Colin Müller
Mechanic LTS



Henrique Rodrigues
Process Engineer ReBCO



Dmitry Sotnikovs
Design Engineer ReBCO



André Brem
Material Scientist



Thomas Michlmayr
CAD, Technical Design

Training – Root Causes

- Resin **cracking**.
- **De-bonding** from winding former or strand diameter.
- **Voids** due to processing → wire movement and/or crack initiation.

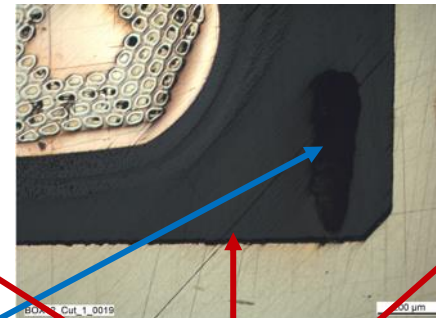
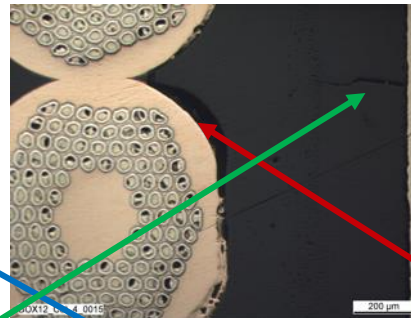
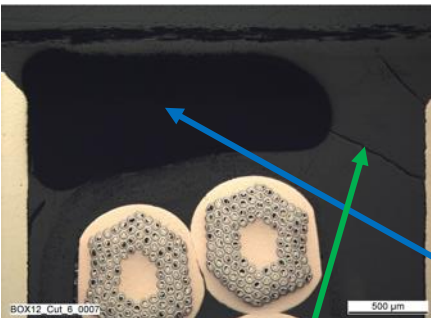
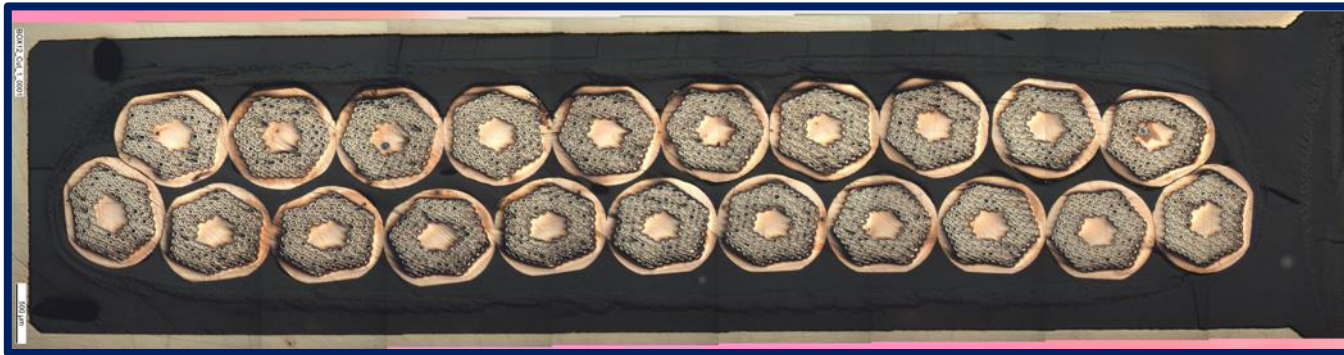

Cracks

Voids

Surface defects (de-bonding)

[Courtesy of O. Kirby, M. Daly.]

[Courtesy D. Arbelaez, LBNL.]

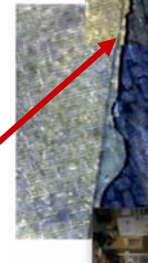

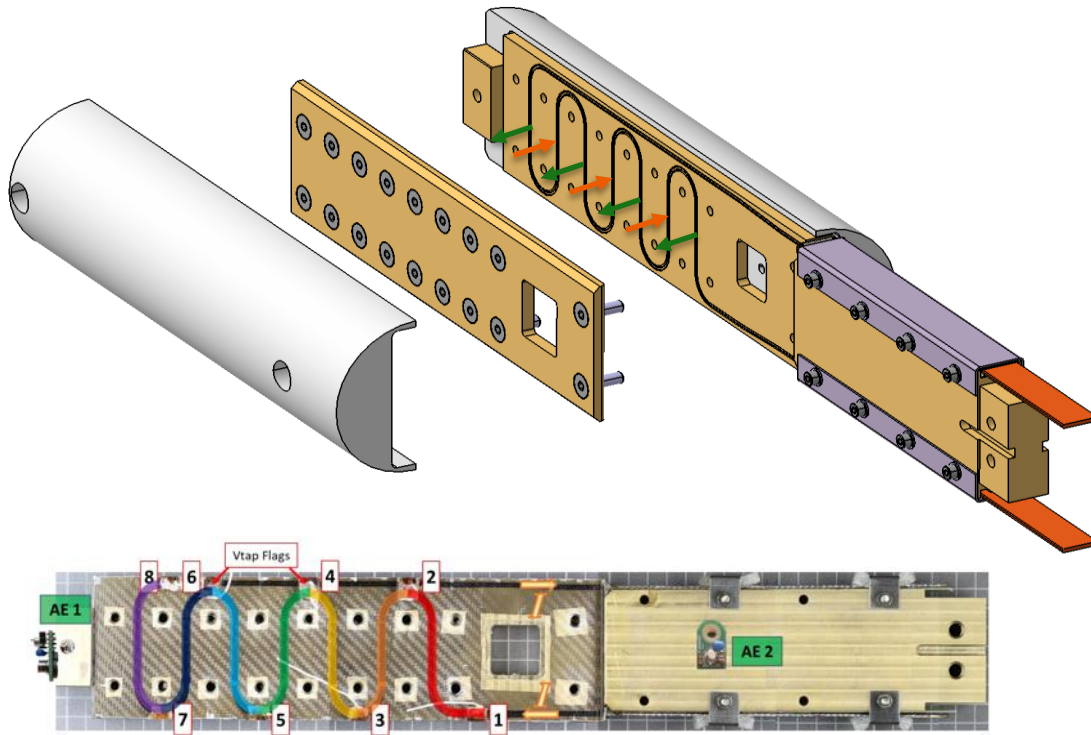

Pictures by M. Daly, S. Sidorov, S. Otten



SC Transformer

11-T solenoid

2PoM01-08
S. Otten

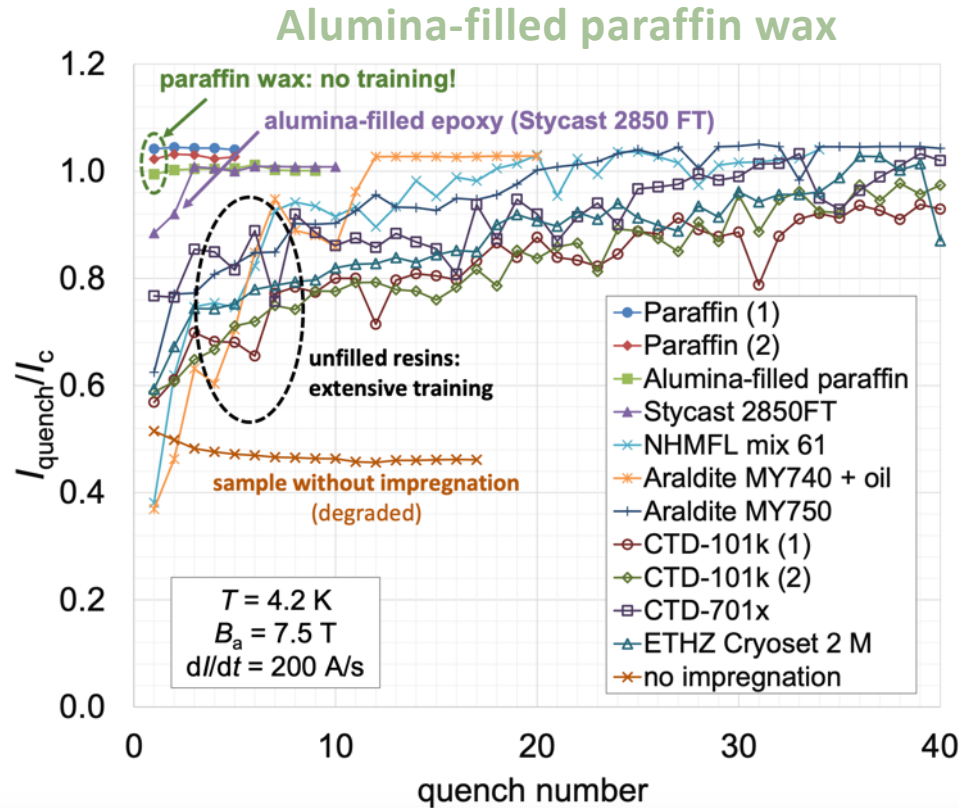

Courtesy, S. Otten, uTwente

BOX (BOnding eXperiment) program with uTwente has shown a wide variety of results, from complete conductor **degradation (no impregnation)** to substantial **training (epoxy)** to **no-training (wax, Stycast, filled wax)**, with **20 BOX samples** successfully and tested to date.

BOX Compression

Successful systems are characterized in U Twente's transverse-compression setup.

CTD 101-K measurements reproduce previous results of Twente U-shaped samples.

Paraffin wax's lower modulus and degradation.

Filled wax bumps wax up to CTD 101-K support.

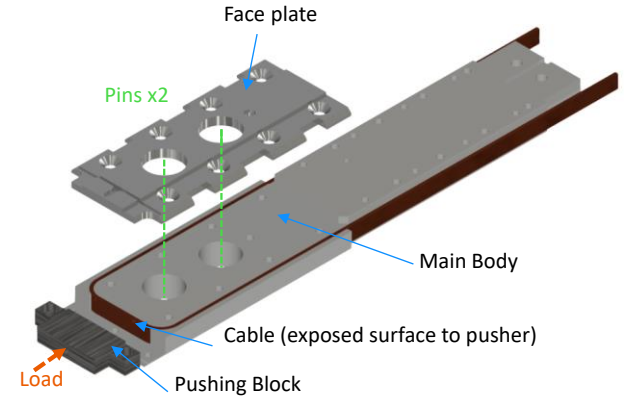
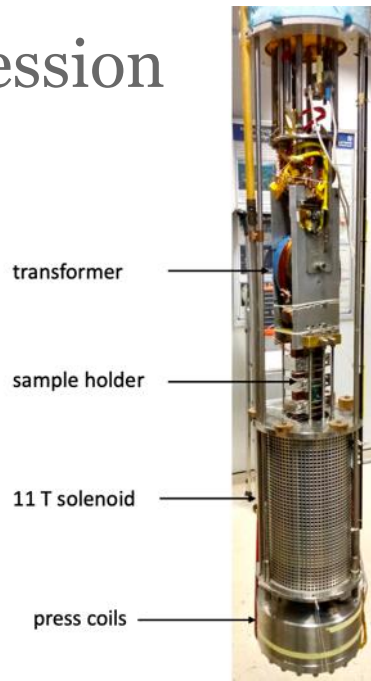

Courtesy M. Daly

2PoM01-07
S. Otten

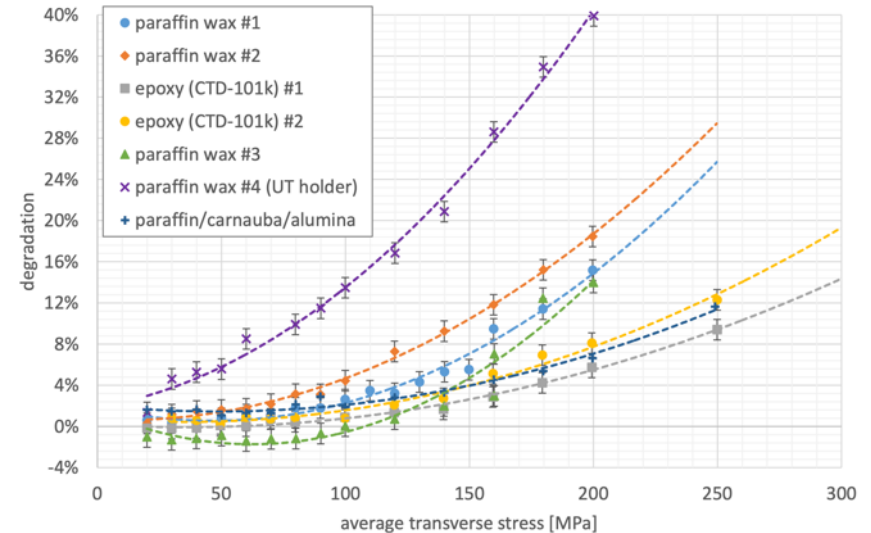
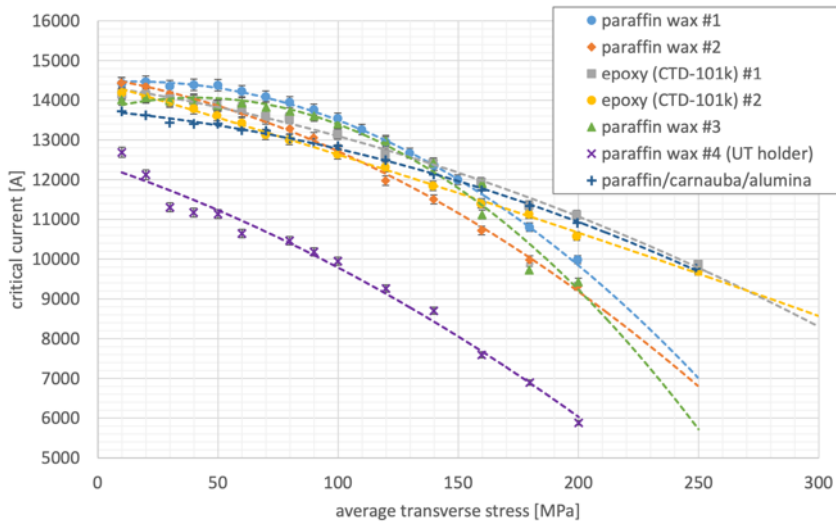

Courtesy S. Ott et al.

Feedback to Magnet Programs

PSI's BigBOX: a 13-turn stress-managed racetrack.

- No training with 12.3 T coil field, 170 MPa coil stress at BNL's DCC17 facility.

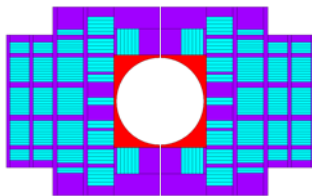
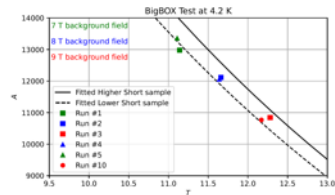
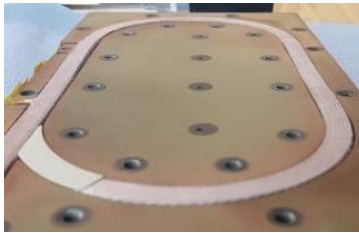

2PoM01-06, D. Araujo

LBNL's wax impregnated sub-scale (5 T) CCT.

- First Nb₃Sn CCT without training.
- Alumina-filled wax considered for CCT6.

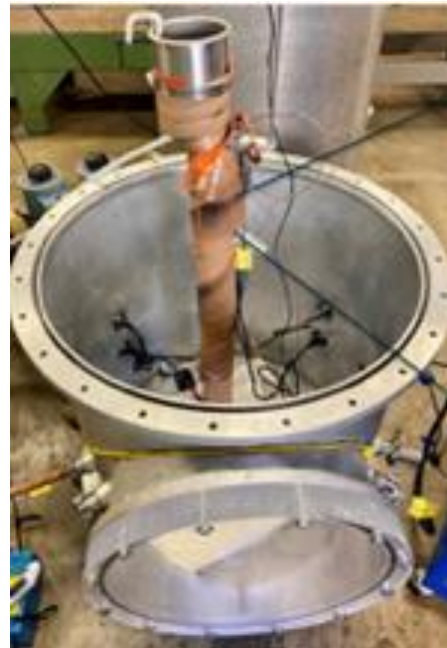

3PoA03-02, D. Arbelaez

Wigner Inst. / CERN collaboration on SuShi septum for FCC-hh

- Wax impregnated CCT required no training to nominal current.

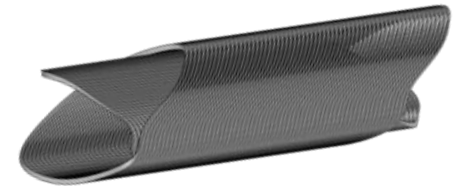

3OrM1-4, D. Barna

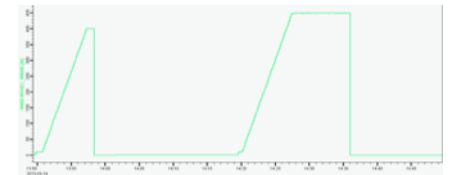

FCC-hh Demonstrator - SMACC

- Goal, demonstrate robust and cost-efficient Nb₃Sn technology for next ESPPU.
- **Novel concept: Stress-managed asymmetric common coils (SMACC).**

Design by D. Araujo.

B_0 target of 14 T

T_{op} : 4.2 K

Eng margin of 10%

$a_x, b_x < 15$ units ($r = 16.67$ mm)
from 1.5 T (injection) to 14 T

I_{op} : 13.1 kA

B_0 short sample @ 1.9 K: 16 T

Intra-beam distance: 300 mm

Clear aperture of 50 mm

Straight-section of 500 mm

Yoke dia: 720 mm

Shell thickness: 35 mm

Total number of coils: 10

Coil types: 3 (re-use of tooling)

Cable types: 3

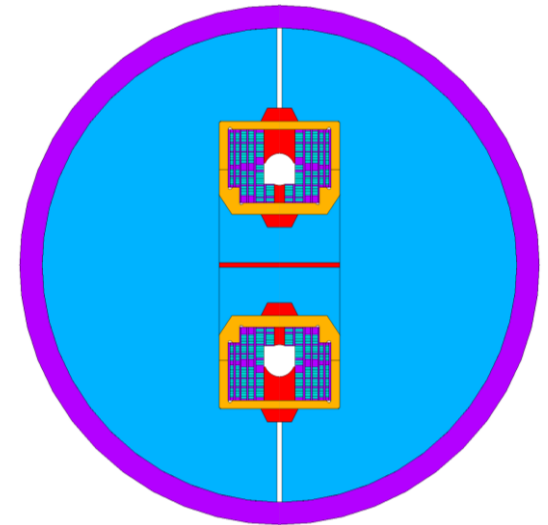
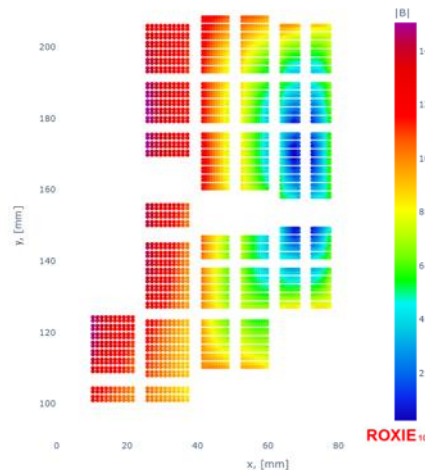

Stainless steel shell
Iron yoke
Coil collar
Former
Non-magnetic poles
Nb₃Sn conductor

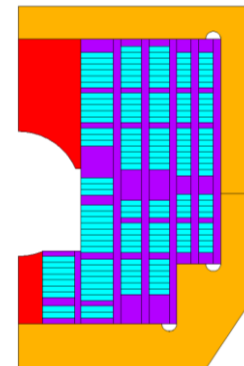

Subscale Technical Design Status

Technical design moving forward; construction for Q2'24.

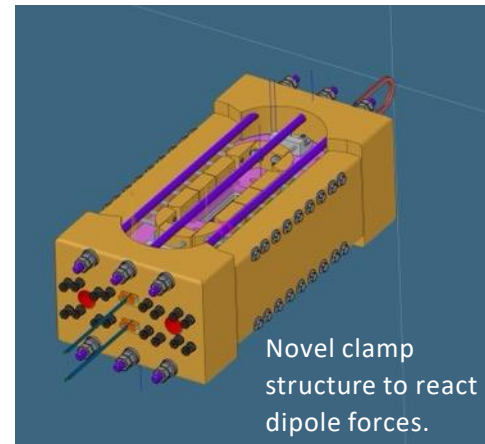
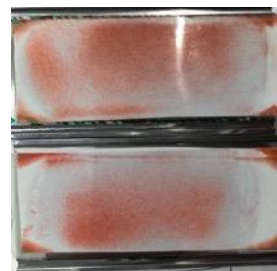
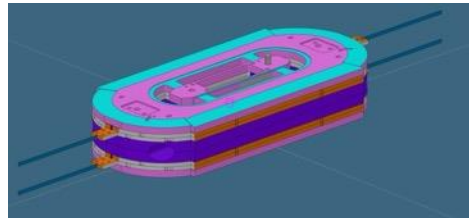
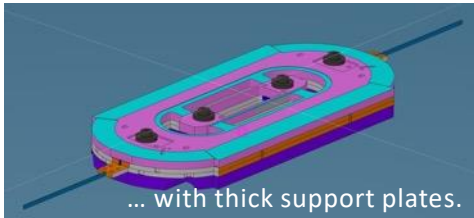
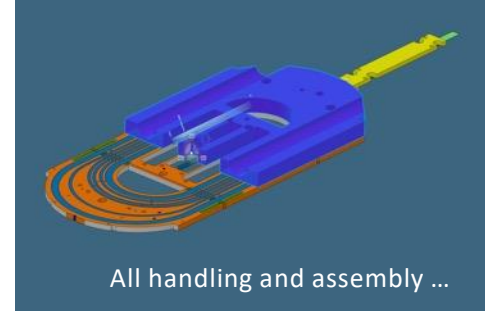
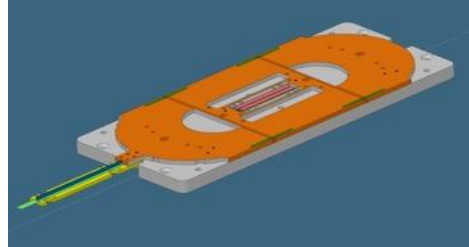
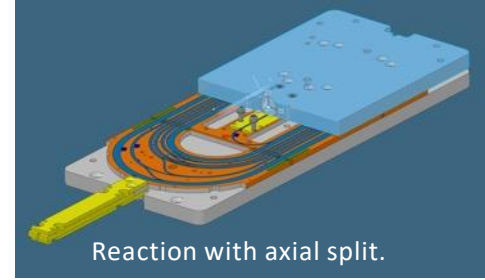
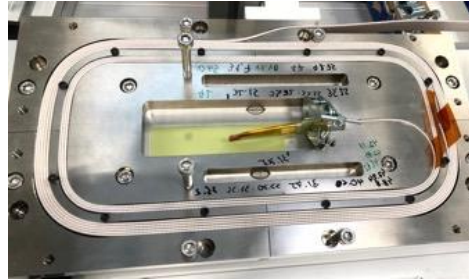
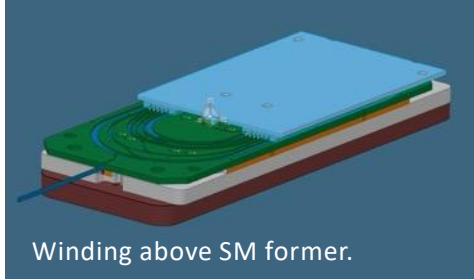

Courtesy T. Michlmayr, D. Araujo, C. Müller, H. Rodrigues

FCC-hh Main Machine Parameters

From F. Gianotti, “Introductory Remarks”, FCC Week 2023, London, UK.

Parameter	FCC-hh		HL-LHC	LHC
collision energy cms [TeV]	80-116		14	14
dipole field [T]	14 (Nb ₃ Sn) – 20 (HTS/Hybrid)		8.33	8.33
circumference [km]	90.7		26.7	26.7
beam current [A]	0.5		1.1	0.58
bunch intensity [10 ¹¹]	1	1	2.2	1.15
bunch spacing [ns]	25	25	25	25
synchr. rad. power / ring [kW]	1020-4250		7.3	3.6
SR power / length [W/m/ap.]	13-54		0.33	0.17
long. emit. damping time [h]	0.77-0.26		12.9	12.9
beta* [m]	1.1	0.3	0.15 (min.)	0.55
normalized emittance [μm]	2.2		2.5	3.75
peak luminosity [10 ³⁴ cm ⁻² s ⁻¹]	5	30	5 (lev.)	1
events/bunch crossing	170	1000	132	27
stored energy/beam [GJ]	6.1-8.9		0.7	0.36
integrated luminosity [fb ⁻¹]	20000		3000	300

Internal Oxidation in prototype multifilamentary wires

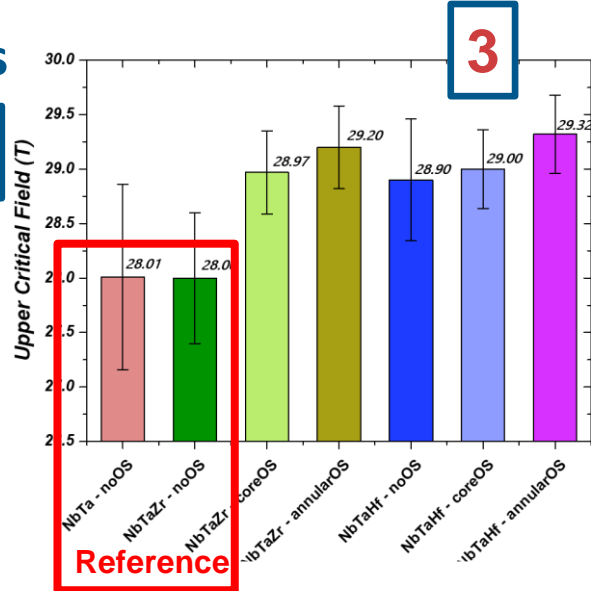
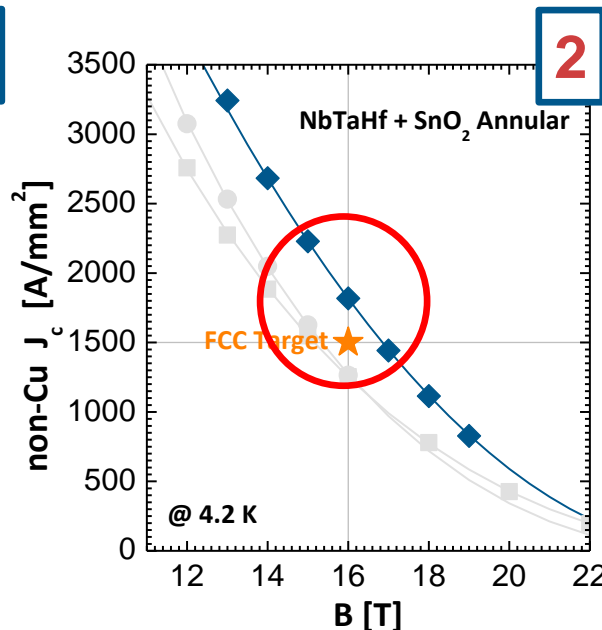
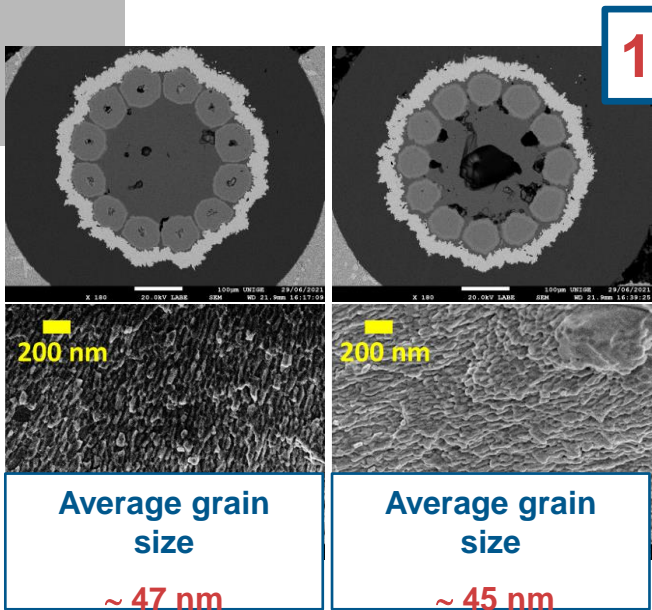

Pushing Nb₃Sn towards its ultimate performance

- 1** Refinement of the grain size: 100 nm → 50 nm
- 2** Large increase of the layer J_c → exceeding the FCC target
- 3** Enhancement of B_{c2} by > 1 T → improved in-field performance



Courtesy of C. Senatore

Development of a single aperture 12 T “robust dipole” in INFN, Genova

Main characteristics :

- ▣ 2 layers ; 50 mm bore
- ▣ Rutherford 40 strands ($\varphi = 1 \text{ mm } J_c(4.5 \text{ K}, 16 \text{ T})=1200 \text{ A/mm}^2$)
- ▣ Nominal magnetic field: 12 T
- ▣ Ultimate (mechanical limit) field: 14 T
- ▣ Short sample limit : 15.7 T
- ▣ Mechanical structure: bladder & key
- ▣ Stress in conductors $\lesssim 150 \text{ MPa}$ in all conditions
- ▣ Outer diameter: 640 mm (LASA test)

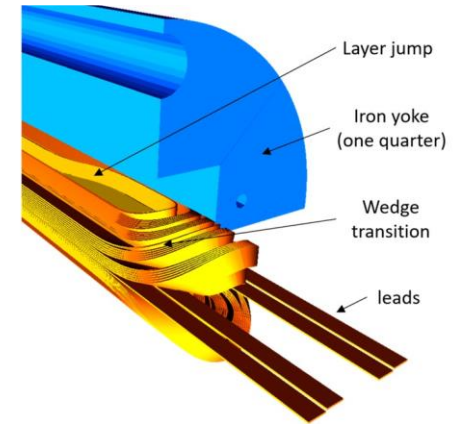
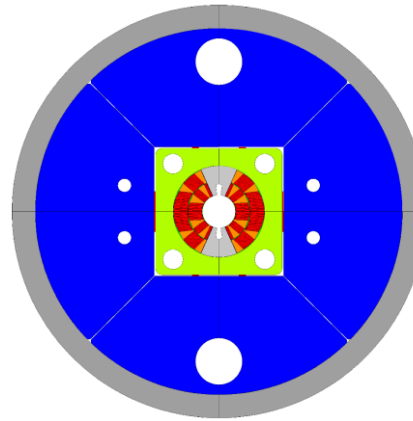

Courtesy of S. Farinon and D. Perini

Development of twin 12 T “robust dipole” at CERN

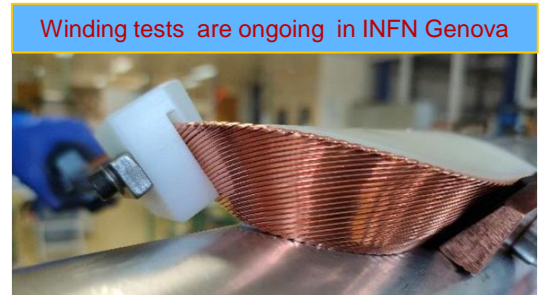
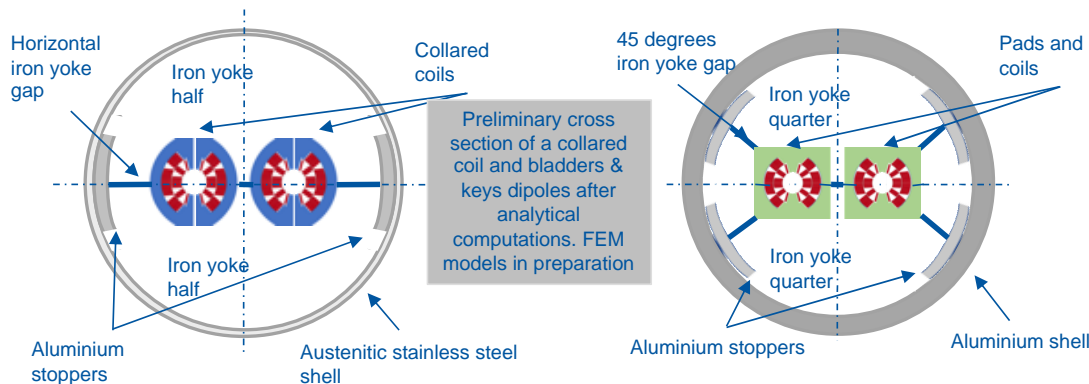

Both the INFN and CERN 12 T short robust dipole models are expected to be ready in 2025



CEA R&D towards 16 T Nb₃Sn block coil



F2D2 Short model → **Planned**
 Grading + Flared-ends + Aperture, 16 T
 1.5 m, 50 mm bore **with aperture**

FD Demonstrator → **Planned**
 Grading + flared-ends, 14 T
 1.5 m, No bore **with flared ends**

CEA-CERN R2D2 → **Ongoing**
 Demonstrate grading ≥ 12 T
 1.5 m, No bore **with grading**

CEA-CERN SMC-11T coil ✓ **Done**
 Demonstrate Nb₃Sn tech. ≥ 12 T

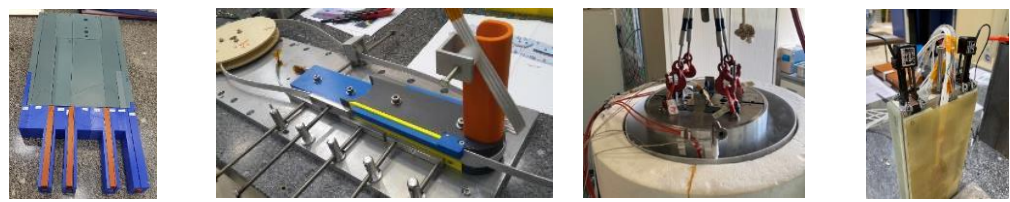
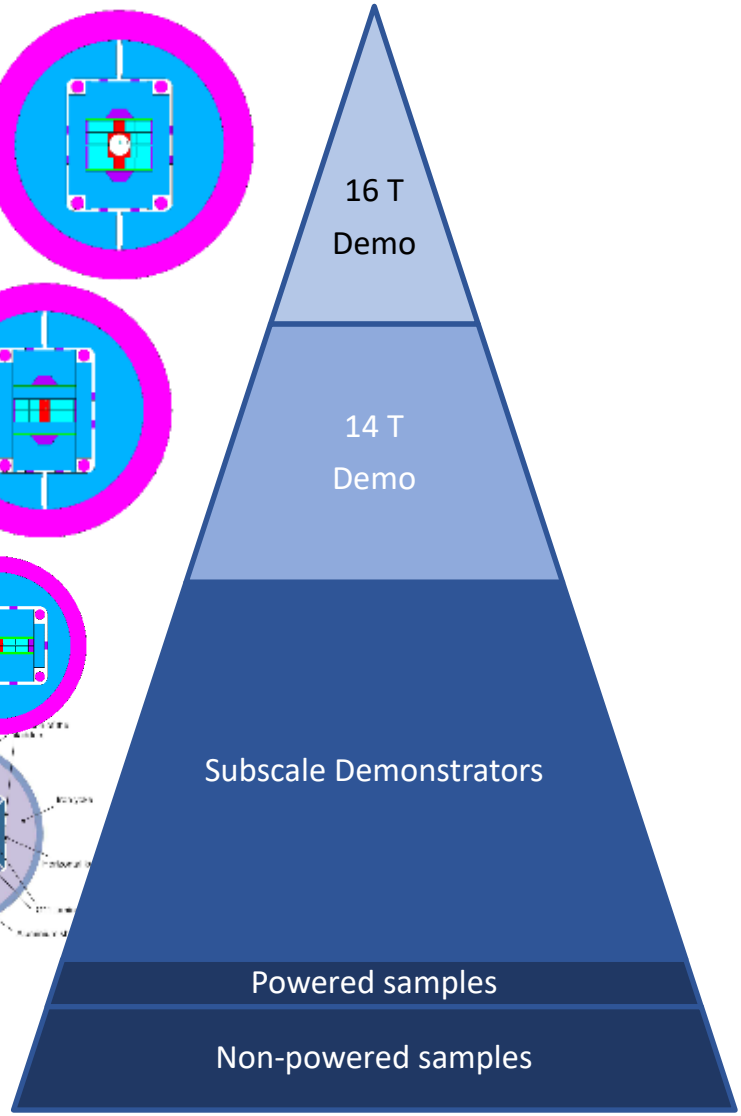
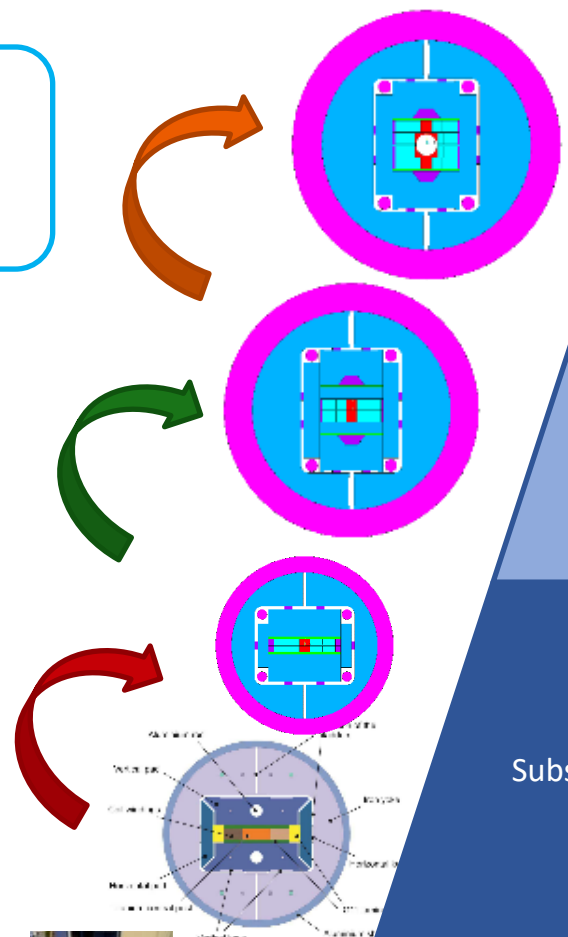

- CHART and MagDev and the HFM Program
- FCC-hh
 - LTS accelerator magnets
 - Main challenges
 - MagDev LTS technology program
 - HTS accelerator magnets
 - the promise
 - the difficulties
 - MagDev HTS technology program
- FCC-ee
 - Technology coils and P3 experiment
 - HTS4
 - MDI
- Muon Collider magnets
- Synergies
 - Neutron scattering
 - RICS proposal
 - Muon target study

HTS in the LDG Accelerator R&D Roadmap

- LDG Roadmap on High-Field Magnets, p. 33
 - “Consideration of only engineering current density would suggest that magnetic fields in the range of 25 T could be generated by HTS”
 - “... performance of HTS in the range 10 to 20 K has reached values of J_e well in excess of 500 to 800 A/mm², i.e., the level that is required for compact accelerator coils. [...] it would open a pathway towards a reduction of cryogenic power, [and] a reduction of helium inventory (e.g., dry magnets)”

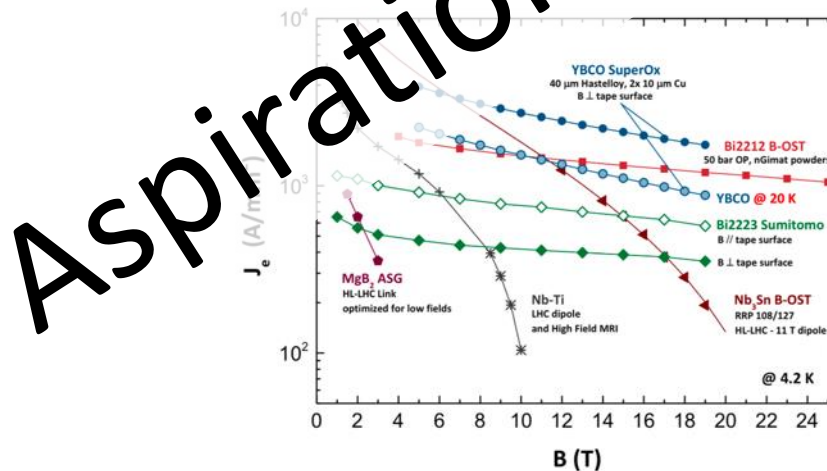

Fig. 2.3: Engineering current density J_e vs. magnetic field for several LTS and HTS conductors at 4.2 K. Latest results for REBCO tapes are reported both at 4.2 K as well as 20 K.

Main Challenges with ReBCO

- **Ramp losses and field quality**
 - LTS wires have filament sizes of few microns (Nb-Ti) to 50 μm (Nb_3Sn).
 - ReBCO tapes are 2-12 mm wide. Screening currents and associated ramp losses are substantially increased.
 - Tape orientation matters!

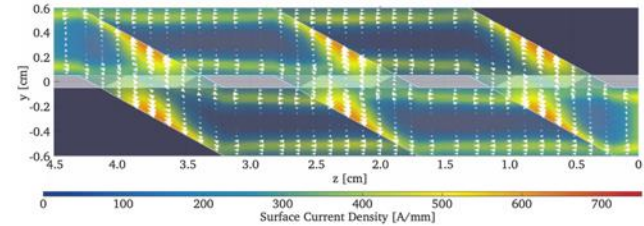

Figure 4.1. Calculated vector field, which indicates the overall current direction for a Roebel cable, shown for an perpendicular uniform applied magnetic field of 0.7T, which was ramped over the virgin curve using a frequency of 0.1 Hz. The operating temperature is set at 4.5 K. The engineering current density of the conductor is scaled to 527 A/mm² at 20 T \perp 4.5 K and 4.4 kA/mm² at 20 T \parallel 4.5 K in the 100 μm thick tape.

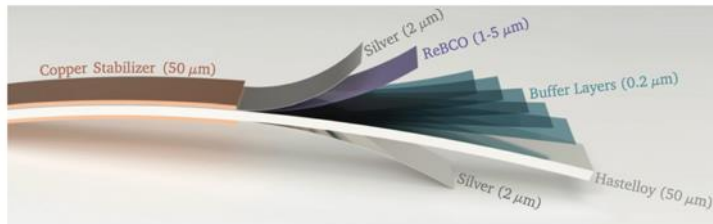

Figure 1.7. Material composition of ReBCO coated conductor. For visual clearness the tape is cut in half along its length such that the inside becomes visible. In reality the copper and the silver layers fully surround the hastelloy substrate carrier.

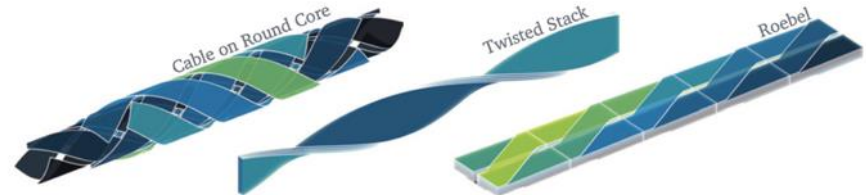
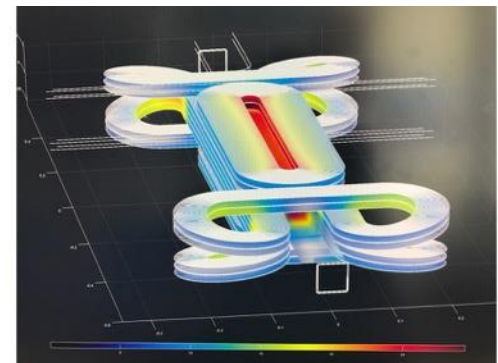

Figure 1.10. Three different geometries for assembling a cable with ReBCO coated conductor. Also refer to Table 1.2.

[J. v. Nugteren, High Temperature Superconductor Accelerator Magnets. PhD thesis, UTwente, 2016.]

- **High-current, low-loss cables with windability**
 - Do we need full transposition (every tape in a cable "sees" the same field, inductive loops are shortened)?
 - Can we pre-fabricate a cable, or do we need to assemble and insulate it "on the fly" during winding?
 - Can the cable withstand pressure of 400+ MPa?



[Courtesy G. Kirby, J. v. Nugteren, J. S. Murtomäki, et al.]

Main Challenges with ReBCO

- **Protection:**

- HTS conductors are intrinsically more thermo-electrically stable than LTS conductors.
- The same margins make detection of quenches and protection from quench-induced damage more challenging.
- Disruptive innovation is required, if we are to account also for
 - quadratic scaling of stored magnetic energy with field,
 - and the fact that cost considerations push magnet engineers towards higher engineering current-densities with lower stabilizing copper fraction.

- **Mechanics:**

- Due to the quadratic scaling with field, mechanics of 20 T magnets is expected to be a formidable challenge.
- The robust operation of novel conductors and cable sin high-stress/strain conditions is yet to be studied.
- New mechanical concepts and novel materials may need to be explored.

J. v. Nugteren, et al., A Fast Quench Protection System for HTS Magnets, IEEE Trans. On Appl. SC, Vol 29, 2018.

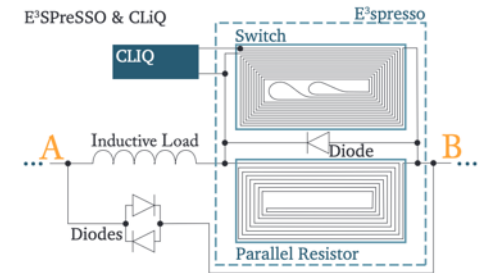

Fig. 4. Schematic showing the electrical connection of the E³SPreSSO unit to the CLIQ box, consisting of a quadrifilar switch and bifilar parallel resistor, and the main inductive load it is protecting.

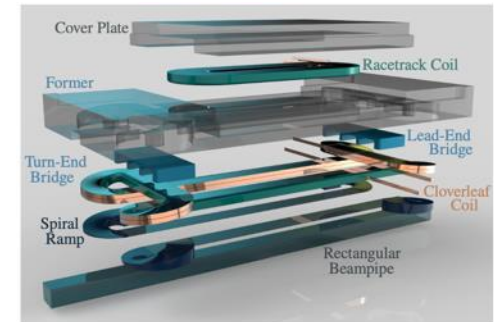

Fig. 11. Exploded view of the conceptual design of the REBCO 20 T+ magnet under development by CERN.

J. v. Nugteren, et al., Towards REBCO 20 T+ Dipoles for Accelerators, IEEE Trans. On Appl. SC, Vol 29, 2018.

Main Challenges with ReBCO

- **Cryogenics**

- Improved Carnot factor can offset increased ramp losses.
- Only if ramp losses can be reduced sufficiently will this lead to a net saving in cooling power!
- FCC-hh has short turnaround time: 6h nominal, 2h for HL-FCC-hh.
- Ramp losses must be extracted quickly from SC coils.
- Increased temperatures (10-20 K) and reduced cryogen inventory will lead to increased temperature gradients within magnets and along cryogenic circuits.
- **Co-development of magnet and cryogenic technologies are essential.**

The Carnot Factor

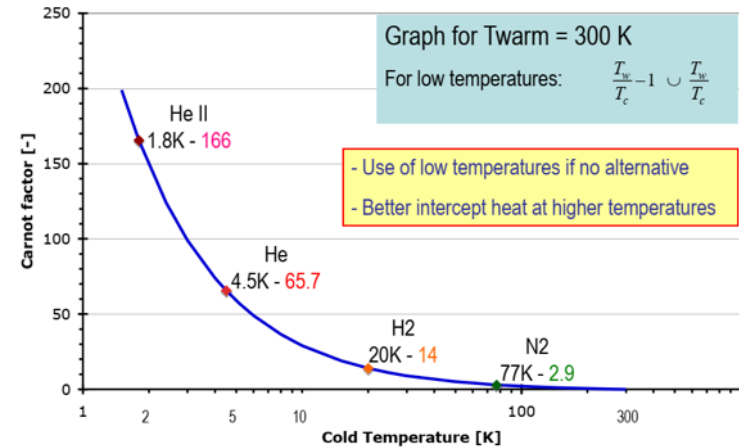

[Serge Claudet, Introduction to Cryogenics for accelerators, CAS on Vacuum for Particule Accelerators Glumslöv-ESS, SE 7-15 June 2017]

Numerical Challenges and Alternative Conductors

- **Numerics**

- Aspect-ratio of physically relevant layers in ReBCO tape make modeling and homogenization in all physical domains difficult.
 - Shielding current calculation
 - Thermal modeling
 - Mechanical behavior
- The community lacks a commonly agreed design approach/tool for HTS magnets.

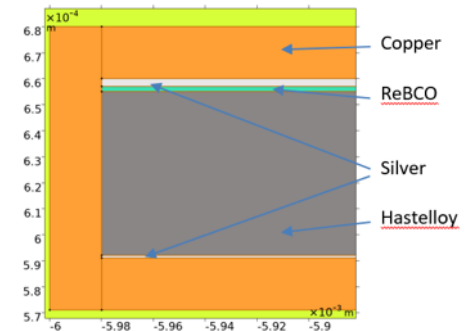
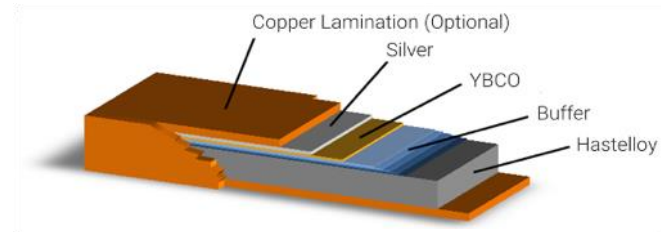

Courtesy D. Sotnikov

- **Conductor-Cost**

- The prediction of ReBCO tape cost is chronically difficult.
- The price slope of the past 10 years predicts that a 10x increase in demand leads to a 2x decrease in cost.
- Compact fusion startups have increased demand towards 10'000 km year.
- FCC may need 1'000'000 km over 10 years.
- Will energy transport applications bring the next step?

Systems Engineering Challenge

- Any future accelerator-magnet system will be strongly coupled to other accelerator subsystems such as cryogenics, beam optics, powering, etc.
- Novel conductors and cryogenics concepts will mean that this coupling is far more consequential and bi-directional than in past accelerators, HL-LHC included.
- New systems-engineering methods of cooperation and negotiation of specifications across subsystem boundaries will be required.
- CHART is developing tools for Model-based systems engineering (MagNum/MagNum2).

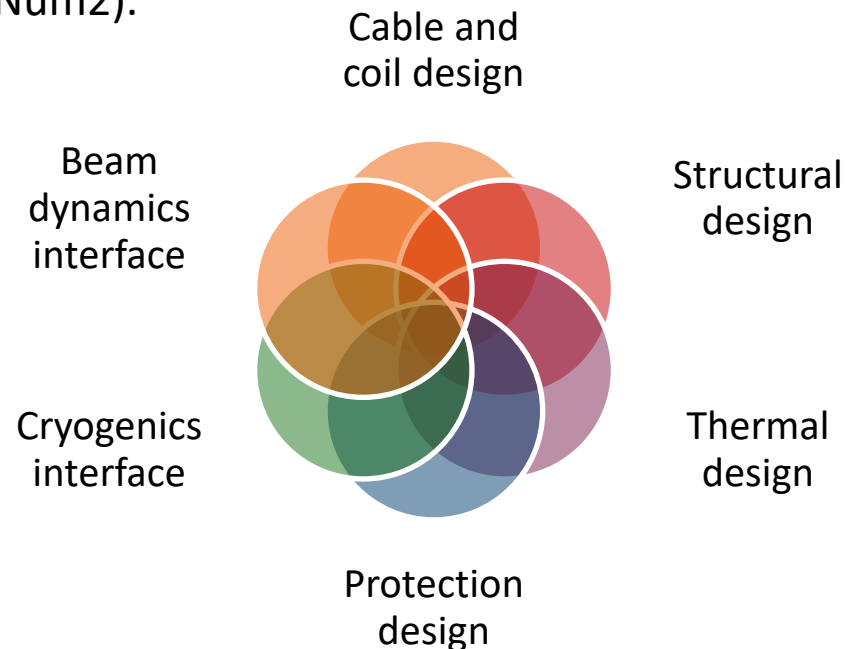

Magnet Technology Readiness Gap

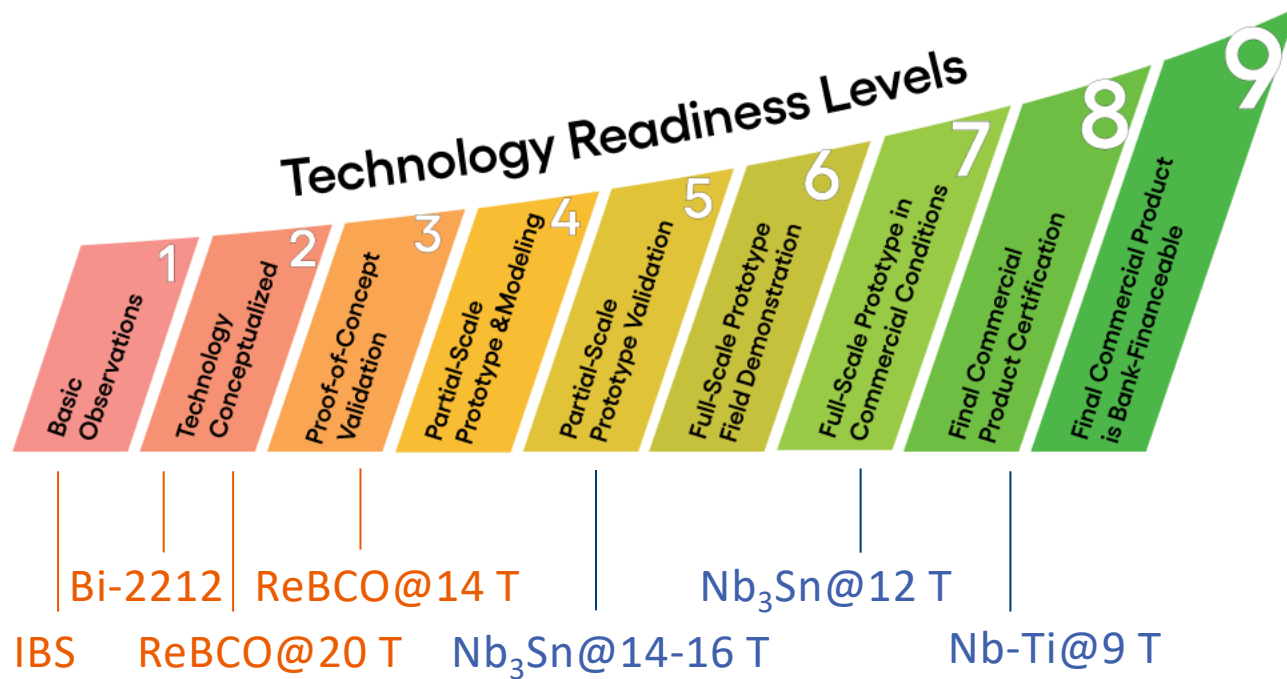

Rough estimates; bottom line is:

HTS technology must catch up to LTS over the coming 10 years in TRL to LTS.

HTS Innovation Funnel for HFM

First deliverable

2023

2023

2024

2025

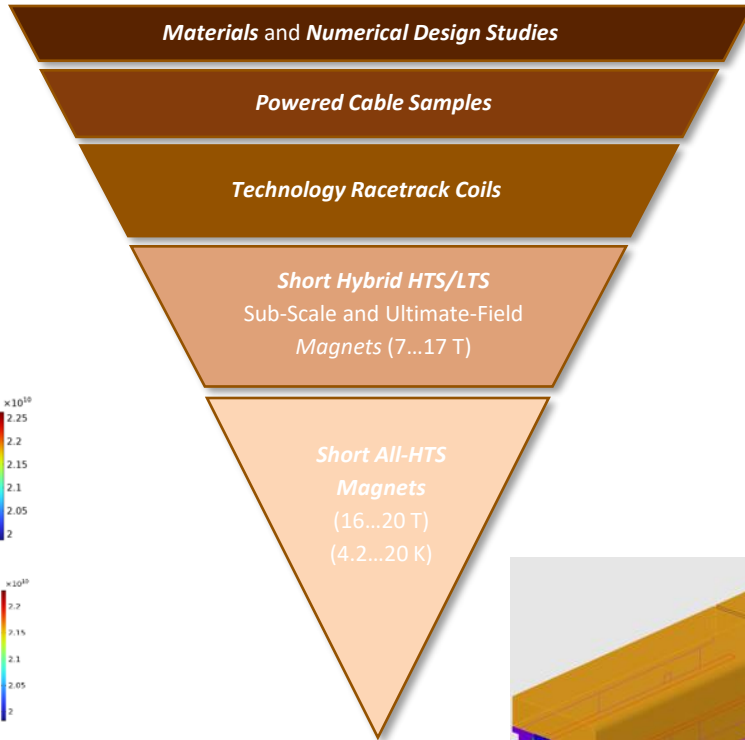

#Deliverables / year

100s

10

2

1

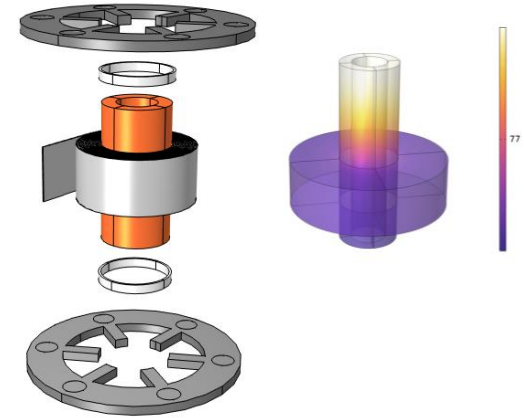

Courtesy D. Sotnikov

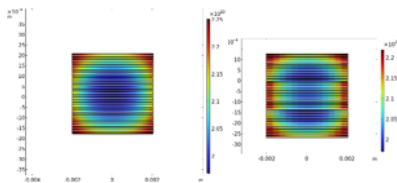
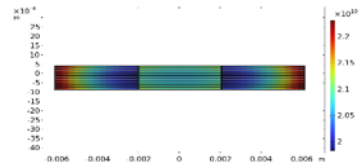
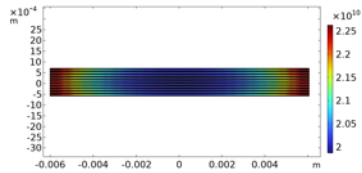

Courtesy D. Sotnikov

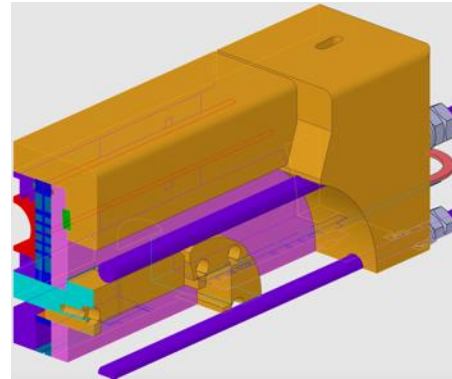

Courtesy D. Araujo, T. Michlmayr



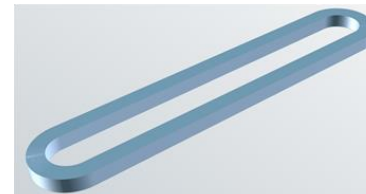
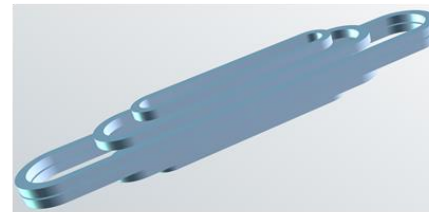
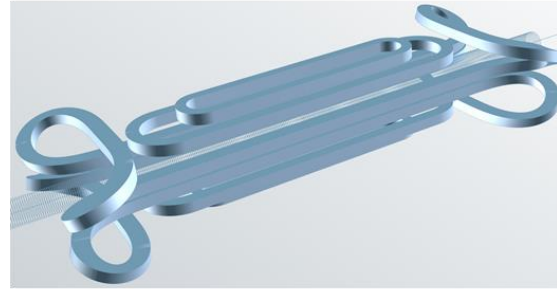
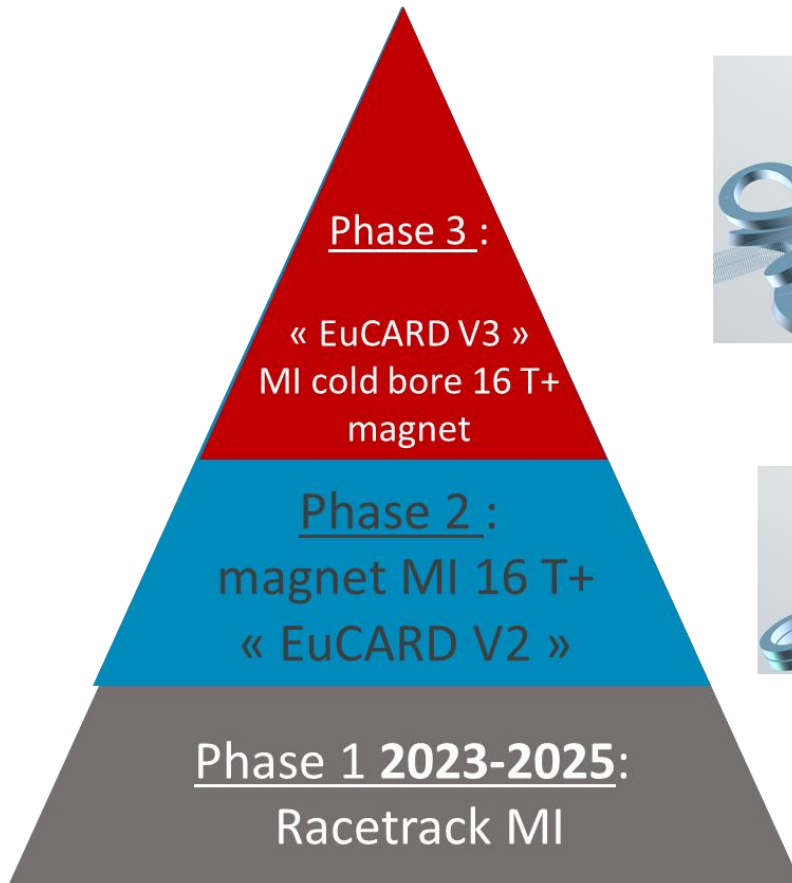

- CHART and MagDev and the HFM Program
- FCC-hh
 - LTS accelerator magnets
 - Main challenges
 - MagDev LTS technology program
 - HTS accelerator magnets
 - the promise
 - the difficulties
 - MagDev HTS technology program
- FCC-ee
 - Technology coils and P3 experiment
 - HTS4
 - MDI
- Muon Collider magnets
- Synergies
 - Neutron scattering
 - RICS proposal
 - Muon target study

Technology Solenoid Program in the Cryogen-free test station

- Successful test in cryogen-free test station of 4-pancake HTS NI solenoid, built in-house at PSI and using licensed Tokamak Energy Ltd technology.
- Coil reached **18.2 T** in the center, **20.3 T** on the conductor at the maximum current of the power converter of 2 kA and 12 K coil temperature.

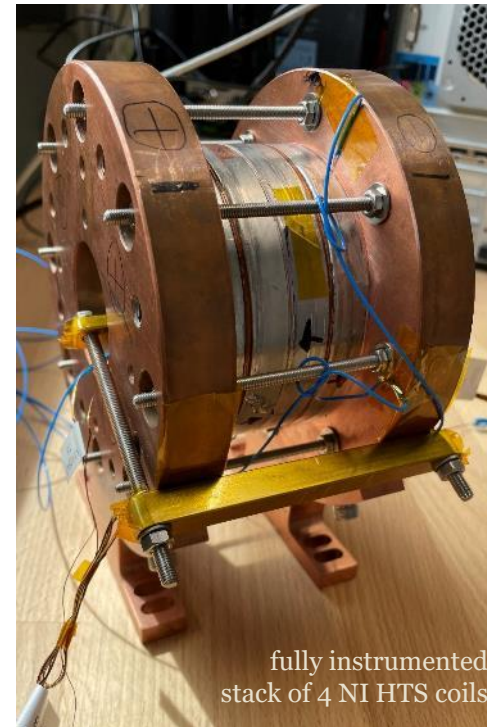
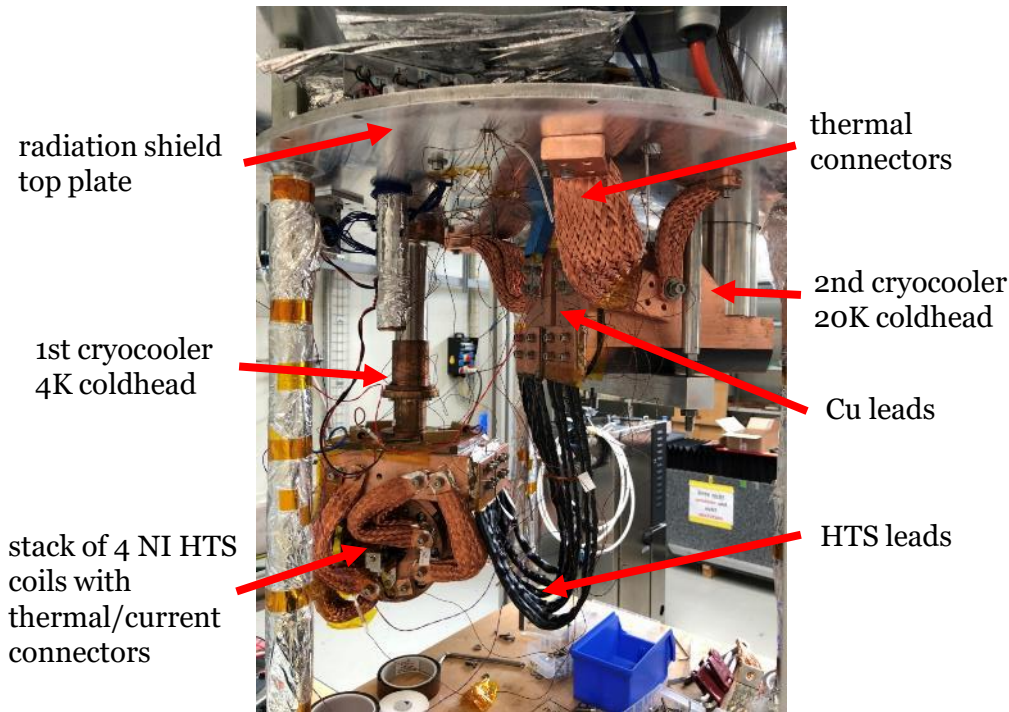

Diameter: 100 mm
Aperture: 50 mm

SC type: ReBCO
tapes: 2
turns: 2 x 170
SC length: 2 x 49 m

Courtesy of M. Duda

Collaboration between PSI and CERN with external partners:

CNRS-IJCLab (Orsay); INFN-LNF (Frascati); SuperKEKB – as observer, also interested in the P³ experiment; INFN-Ferrara – radiation from crystal

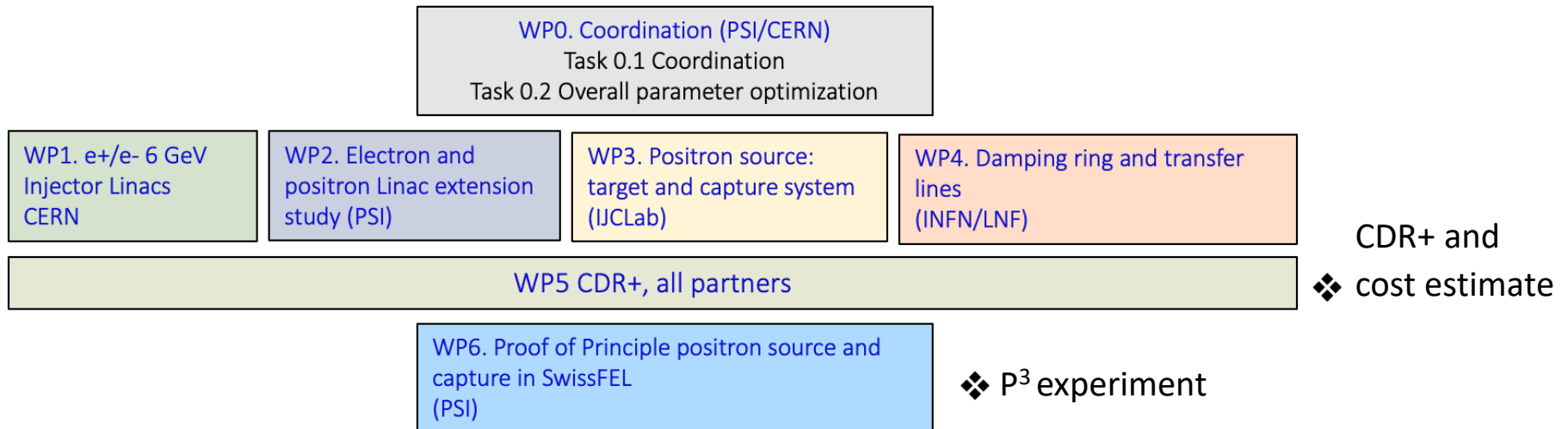

See: M. Schär, CHART Annual Meeting, <https://indico.psi.ch/event/14732/>

PSI Positron Production (P3) Experiment

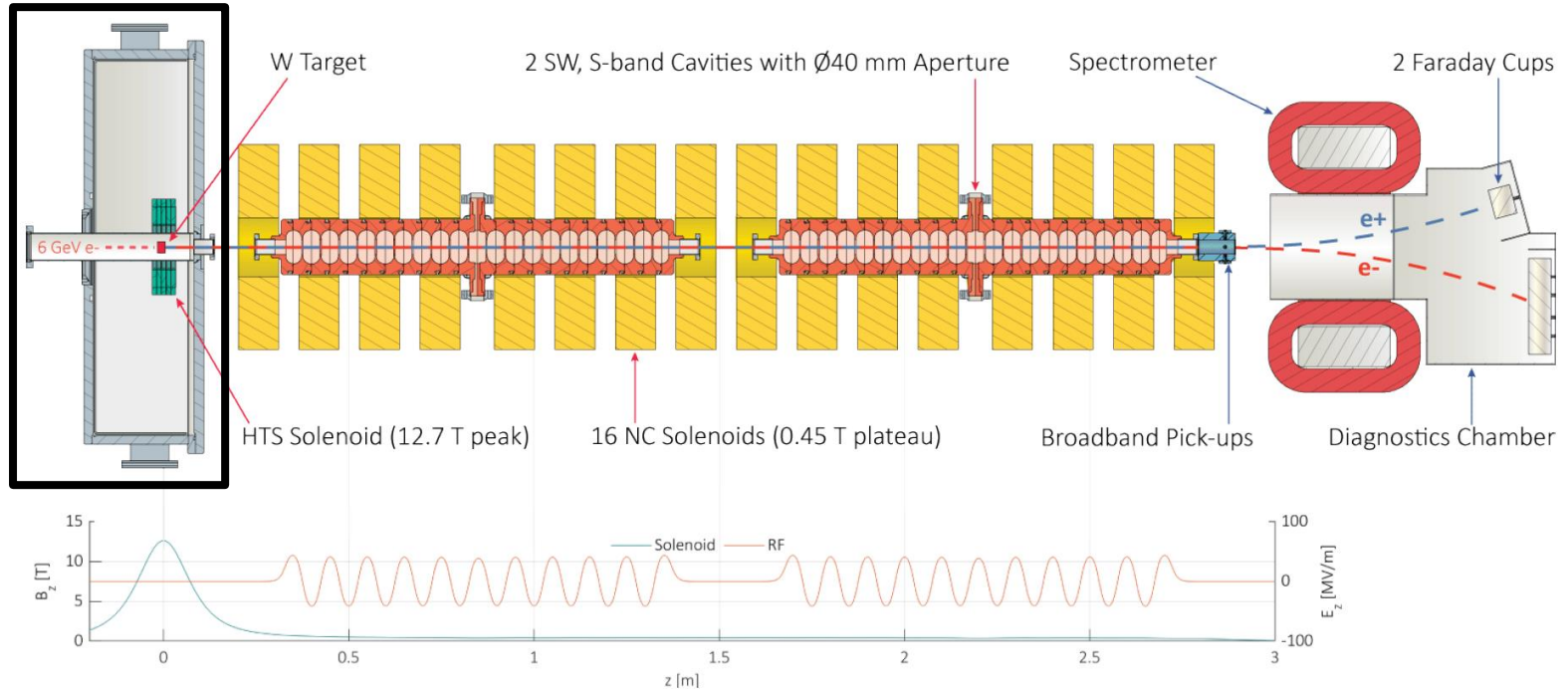

See: M. Schär, CHART Annual Meeting, <https://indico.psi.ch/event/14732/>

- High e+ yield at DR is enabled to great extent by:
 - High e- energy
 - Strong solenoid fields around target and along capture linac
 - Large aperture

	SLC (SLAC)	SuperKEKB (KEK)	P ³ (PSI)
	1989 - 1998	ca. 2014 -	ca. 2026
Primary e- energy [GeV]	30 - 33	3.5	6
Max. sol. field at Target [T]	5.5	3.5	12.7
Avg. sol. field along linac [T]	0.5	0.4	0.45
Min. RF cavity aperture [mm]	18	30	40
e+ yield at target exit	~30	~8	13.77
Max. meas. e+ yield at DR	~2.5	~0.4	~5.64

*expected at Faraday Cups

- J. E. Clendenin, *High-Yield Positron Systems for Linear Colliders*, in Proc. PAC'89, Chicago, USA (1989), pp. 1107–1112
- Chaikovska et al., *Positron sources: from conventional to advanced accelerator concepts-based colliders*, JINST, 17, P05015 (2022)
- SLAC Linear Collider Design Handbook, SLAC-R-714 (1984).
- Akai, K. Furukawa and H. Koiso, *SuperKEKB Collider*, Nucl. Instrum. Methods Phys. Res., Sect. A 907, 188 (2018).
- T. Suwada et al., *First simultaneous detection of electron and positron bunches at the positron capture section of the SuperKEKB factory*, Sci Rep 11, 12751 (2021).

See: N. Vallis, Swiss Physical Society Annual Meeting, <https://indico.cern.ch/event/1252545/>

P³ Capture solenoid

HTS NI target solenoid, to demonstrate high-yield positron source concept

- stable DC operation,
- high thermal conduction due to solde impregnation to extract heat deposited in coils,
- radiation robustness due to absence of insulators.

All components in procurement.

Construction starting soon.

Experiment at PSI's SwissFEL 2026

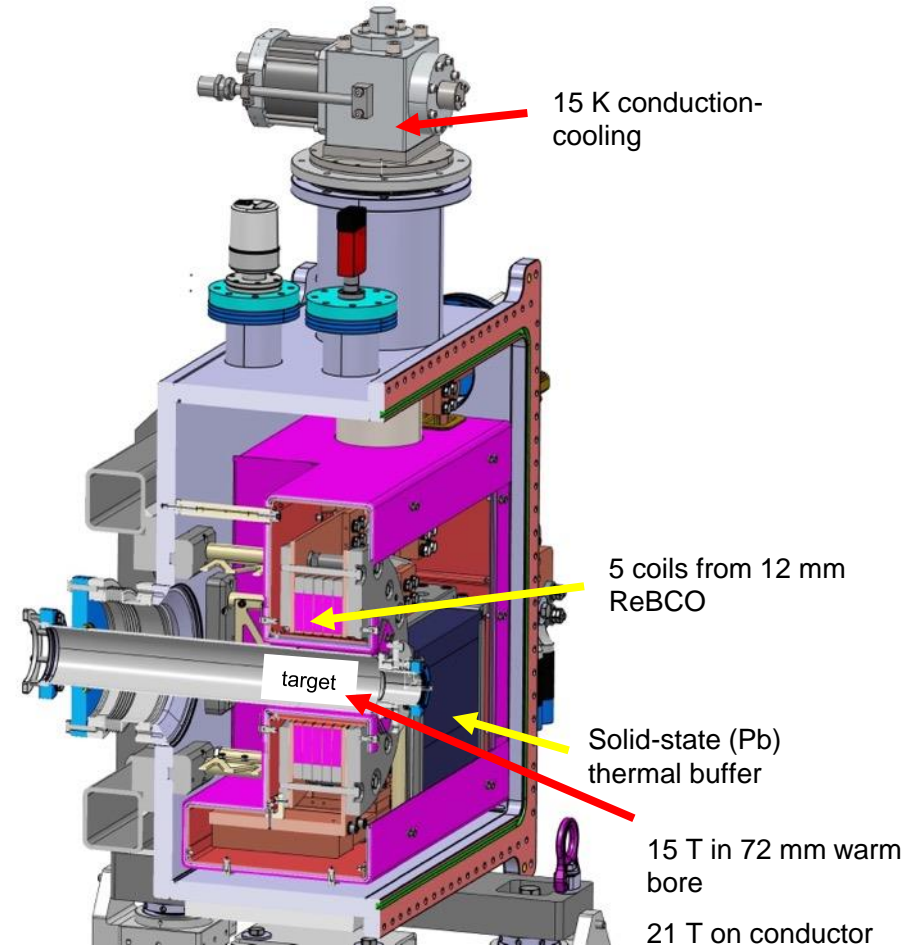
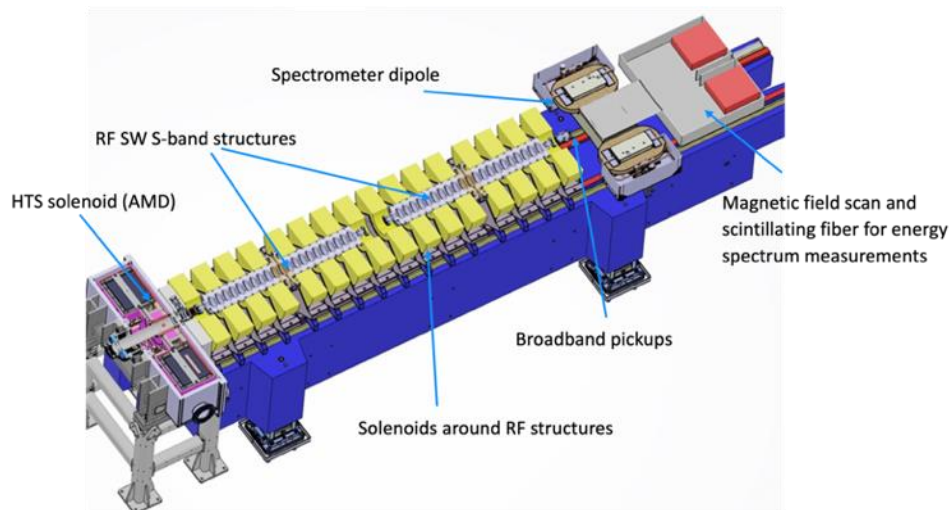

Coil diameter	122 mm inner, 219 mm outer
Stored energy	331 kJ
Operating current	1.17 kA
Charging constant	11 hours

Courtesy J. Kosse, T. Michlmayr, H. Rodrigues

FCC-ee NC Magnets

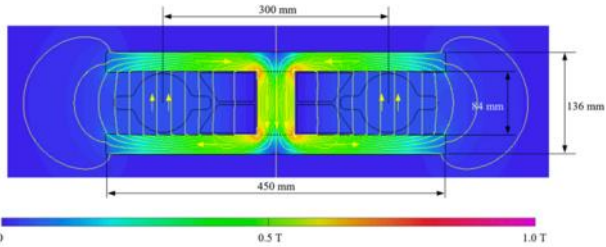

Fig. 3.1. Cross-section of the main bending magnet; the flux density corresponds to 57 mT in the gap; the outline of vacuum chambers with side winglets is also shown.

2900 magnets
 Strength: 57 mT
 Apert.: 130x84 mm
 Power: 13.3 MW

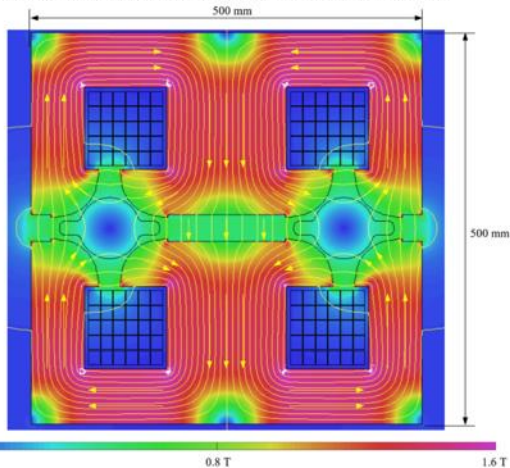

Fig. 3.3. Cross-section of the FCC-ee main quadrupole, for a 10 T/m gradient.

2900 magnets
 Strength: 10 T/m
 ID: 84 mm
 Power: 22.6 MW

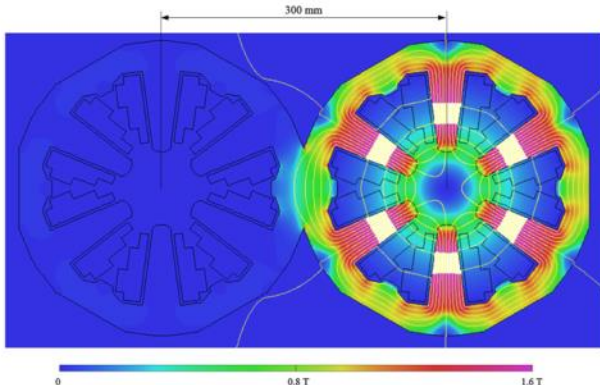

Fig. 3.6. Cross-section of the FCC-ee main sextupole magnet. The position of the sextupole for the other beam is outlined on the left.

4672 magnets
 Strength: 807 T/m²
 ID: 76 mm
 Power: 20.5 MW

Table 3.1. Parameters of the main bending magnets.

Strength, 45.6 GeV–182.5 GeV	mT	14.1–56.6
Magnetic length	m	21.94/23.94
Number of units per ring		2900
Aperture (horizontal × vertical)	mm	130 × 84
Good field region (GFR) in horizontal plane	mm	±10
Field quality in GFR (not counting quadrupole term)	10 ⁻⁴	≈1
Central field	mT	57
Expected b_2 at 10 mm	10 ⁻⁴	≈3
Expected higher order harmonics at 10 mm	10 ⁻⁴	j1
Maximum operating current	kA	1.9
Maximum current density	A/mm ²	0.79
Number of busbars per side		2
Resistance per unit length (twin magnet)	μΩ/m	22.7
Maximum power per unit length (twin magnet)	W/m	164
Maximum total power, 81.0 km (interconnections included)	MW	13.3
Inter-beam distance	mm	300
Iron mass per unit length	kg/m	219
Aluminium mass per unit length	kg/m	19.9

Table 3.2. Parameters of the main quadrupole magnets.

Maximum gradient	T/m	10.0
Magnetic length	m	3.1
Number of twin units per ring		2900
Aperture diameter	mm	84
Radius for good field region	mm	10
Field quality in GFR (not counting dip. term)	10 ⁻⁴	≈1
Maximum operating current	A	474
Maximum current density	A/mm ²	2.1
Number of turns		2 × 30
Resistance per twin magnet	mΩ	33.3
Inductance per twin magnet	mH	81
Maximum power per twin magnet	kW	7.4
Maximum power, 2900 units (with 5% cable losses)	MW	22.6
Iron mass per magnet	kg	4400
Copper mass per magnet (two coils)	kg	820

Table 3.3. Parameters of the main sextupole magnets.

Maximum strength, B''	T/m ²	807.0
Magnetic length	m	1.4
Number of units per ring		208 × 4 = 832 (Z, W) 292 × 8 = 2336 (H, tt̄)
Number of families per ring		208 (Z, W) 292 (H, tt̄)
Aperture diameter	mm	76
Radius for good field region (GFR)	mm	10
Field quality in GFR	10 ⁻⁴	≈1
Ampere turns	A	6270
Current density	A/mm ²	7.8
Maximum power per single magnet at 182.5 GeV	kW	15.5
Average power per single magnet at 182.5 GeV	kW	4.4
Total power at 182.5 GeV (4672 units)	MW	20.5

By using **HTS sextupoles and quadrupoles** instead of the RT baseline, HTS4 aims to:

- **Reduce energy consumption** from up to 80 MW (43 MW in CDR) to ~10 MW
- Increase dipole filling factor – decrease SR
- Enhance optics flexibility

Challenges:

- **Accelerator-grade field quality** with HTS
- Balance **cooling** power with **conductor** volume
- **High-reliability** cryocooler-based operation
- **Low heat-load** powering
- Mitigation of **radiation** issues on electronics

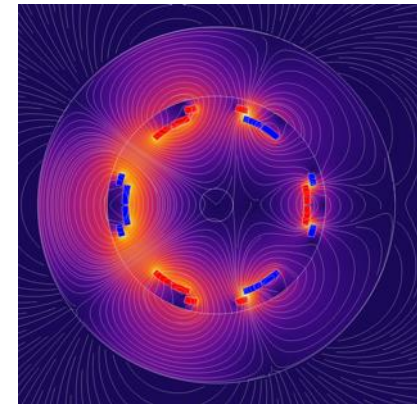

Cosine-theta variant courtesy J. Kosse

Sub-scale coils (start Q4'23) and **1-m prototype module** to be constructed and tested at PSI.

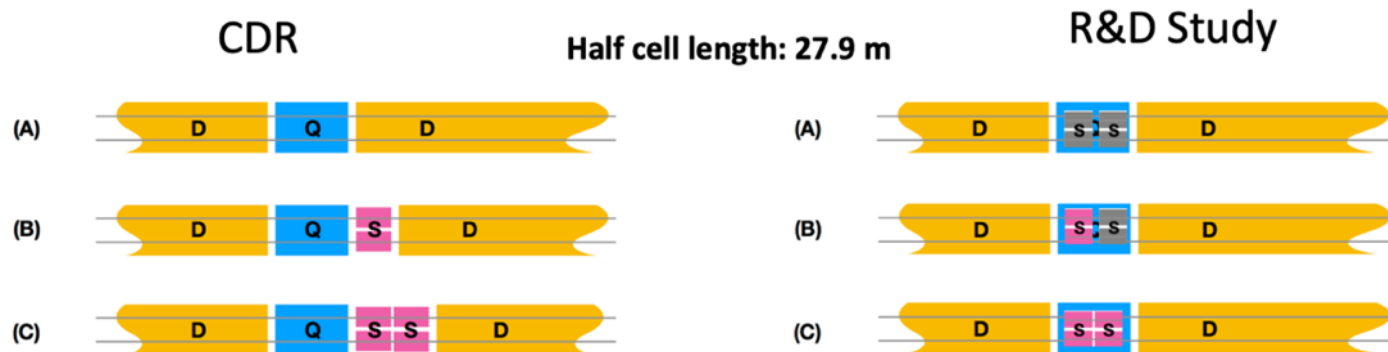

- In support of FCCee HTS4, CPES develops a cryogenic power supply which, in its first iteration, may reduce heat load to the cryo-cooler by 50%.
- CPES development follows specifications provided by CERN power-supply specialists.
- The CPES unit may incorporate magnet protection functionality.
- Cold-testing and integration studies at PSI cryogen-free test station.

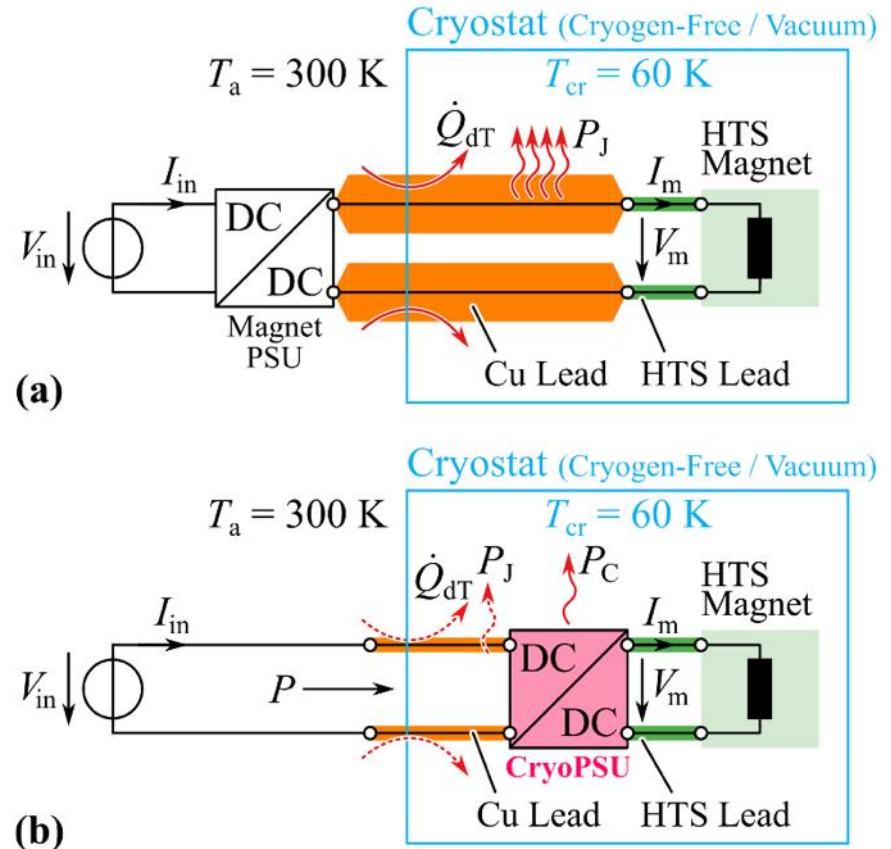

Courtesy J. Huber

- 22 superconducting magnets:
 - 6 final focus (ID 40 mm, 100 T/m),
 - 12 correctors
 - 2 compensation solenoids (4.9 T, 118-195 mm tapered)
 - 2 screening solenoids (2 T, OD 390 mm)
- Most located SC magnets in the heart of the detector.
- High complexity due to multiple strongly coupled systems: IP, detector solenoid (forces and protection), mechanics and alignment, beam dynamics, etc.

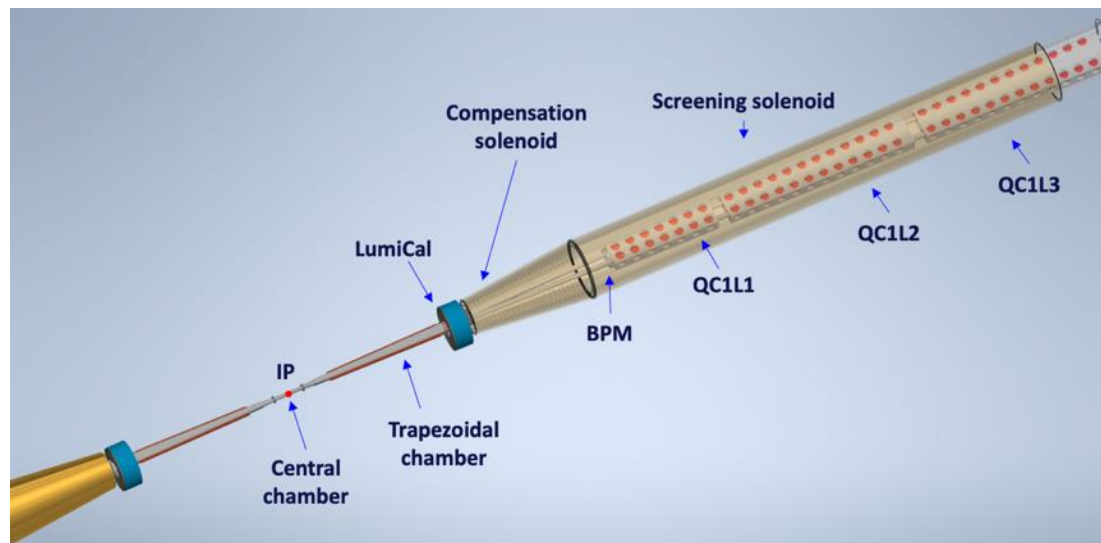

FCC-ee Final Focus Quadrupoles

- Current final focus design based on CCT concept.
- Room-temperature measurement of field quality < 0.15 units.
- May soon be impregnated with wax at PSI.
- To be tested at cold at CERN.

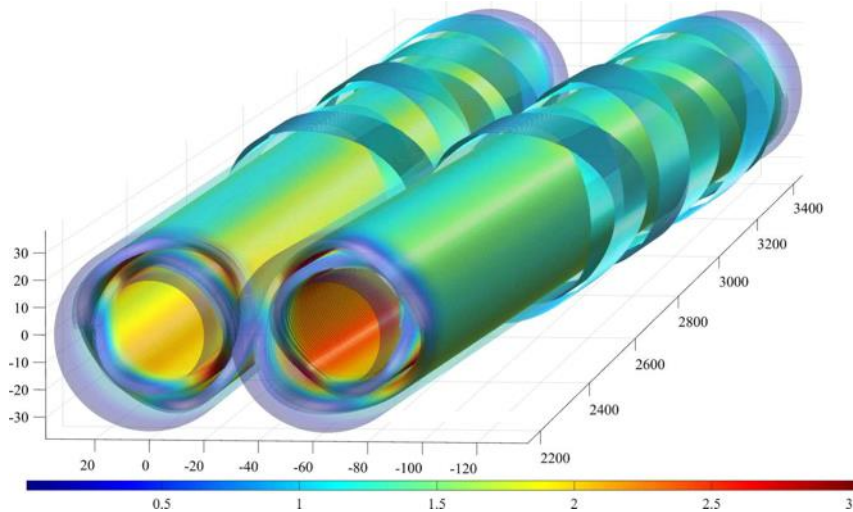

[M. Koratzinos, Pre-engineering design review and roadmap discussion for FCC-ee IR magnets, April 2022]

MAGNETIC MEASUREMENTS AT WARM OF THE FIRST FCC-EE FINAL FOCUS QUADRUPOLE PROTOTYPE

M. Koratzinos¹, MIT, G. Kirby, C. Petrone and M. Liebsch, CERN

Abstract

The first FCC-ee final focus quadrupole prototype has been designed, manufactured, assembled and tested at warm. The prototype is a single aperture quadrupole magnet of the CCT type. One edge of the magnet was designed with local multipole cancellation, whereas the other was left with the conventional design. An optimized rotating induction-coil sensor was used. A technique was developed to take into account field distortions due to the environment of the test and distinguish them from magnet effects, demonstrating an excellent field quality for the prototype.

other. The idea behind the edge correction is this: a CCT magnet has non-zero multipole components at the edges, which exactly integrate to zero when integrating over the whole magnet. However, this magnet will be placed in an area of rapidly changing optics functions, and therefore global compensation is not sufficient. Instead, all multipoles vanish locally at the edge of the magnet using the technique described in [3]. *Figure 1* shows the inner magnet former on the corrected edge.

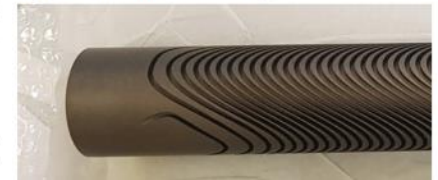

INTRODUCTION

The FCC project aims to deliver a high-luminosity e^+e^- storage ring with a range of energies from 45 to 182.5 GeV per beam (FCC-ee) [1] [2]. It incorporates a “crab waist”

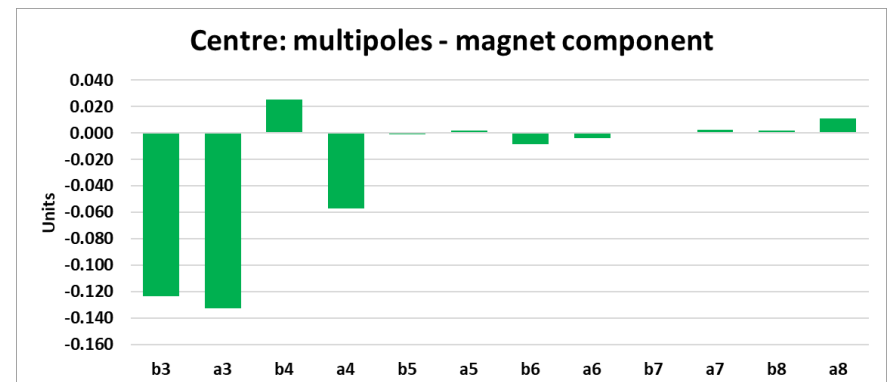

- CHART and MagDev and the HFM Program
- FCC-hh
 - LTS accelerator magnets
 - Main challenges
 - MagDev LTS technology program
 - HTS accelerator magnets
 - the promise
 - the difficulties
 - MagDev HTS technology program
- FCC-ee
 - Technology coils and P3 experiment
 - HTS4
 - MDI
- **Muon Collider magnets**
- Synergies
 - Neutron scattering
 - RICS proposal
 - Muon target study



Muon Collider magnets

20 T, 200 mm

HTS !

Radiation heat load $\approx 5 \dots 10$ kW

Radiation dose: 80 MGy

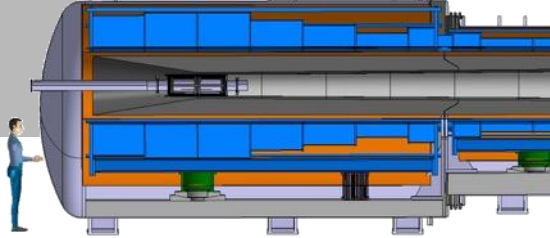

NC ± 1.8 T, 400 Hz
100 mm x 30 mm

SC < 10T

100 mm x 30 mm

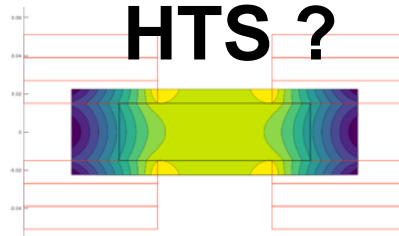

HTS ?

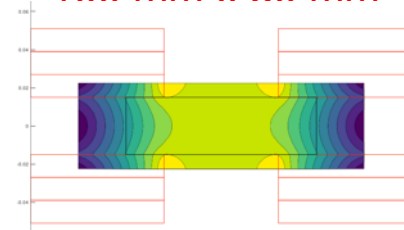
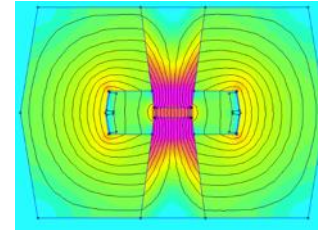

SC dipole

NC dipole

NC dipole

SC dipole

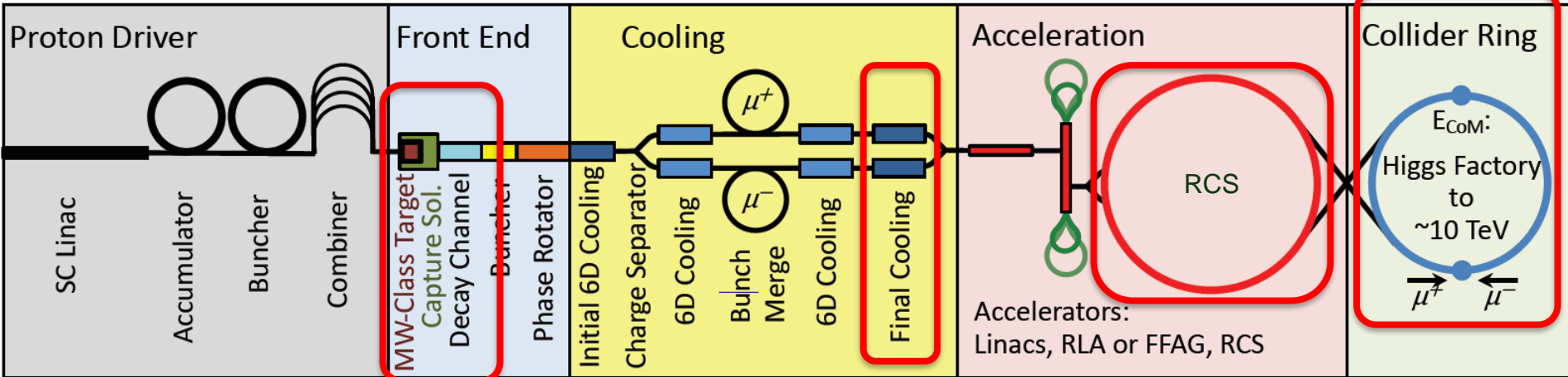

> 40 T, 60 mm

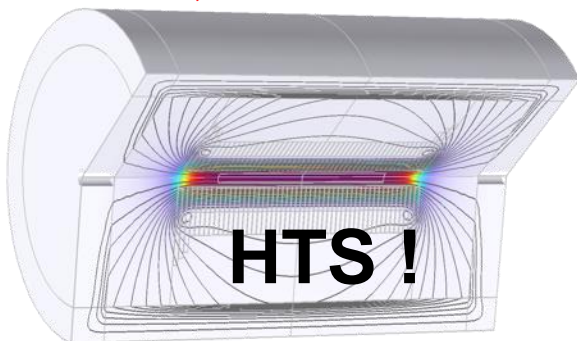

16 T peak, 150 mm
Radiation heat load ≈ 5 W/m
Radiation dose $\approx 20 \dots 40$ MGy

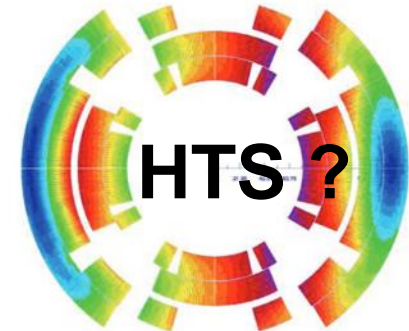
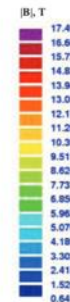

- CHART and MagDev and the HFM Program
- FCC-hh
 - LTS accelerator magnets
 - Main challenges
 - MagDev LTS technology program
 - HTS accelerator magnets
 - the promise
 - the difficulties
 - MagDev HTS technology program
- FCC-ee
 - Technology coils and P3 experiment
 - HTS4
 - MDI
- Muon Collider magnets
- Synergies
 - Neutron scattering
 - RICS proposal
 - Muon target study

Split Solenoid for Neutron Scattering?

18 T NI HTS solenoid

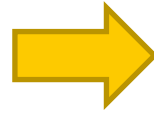

10 mm split NI HTS solenoid

18 T at 2 kA, 12 K
4 coils

Predict with simulation

~18 T at max 2 kA
6 coils

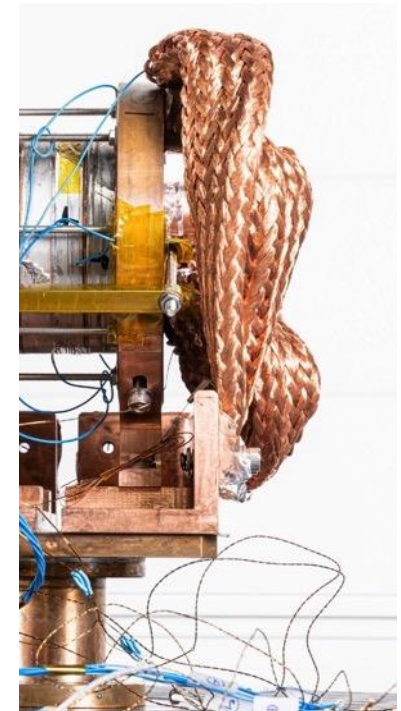
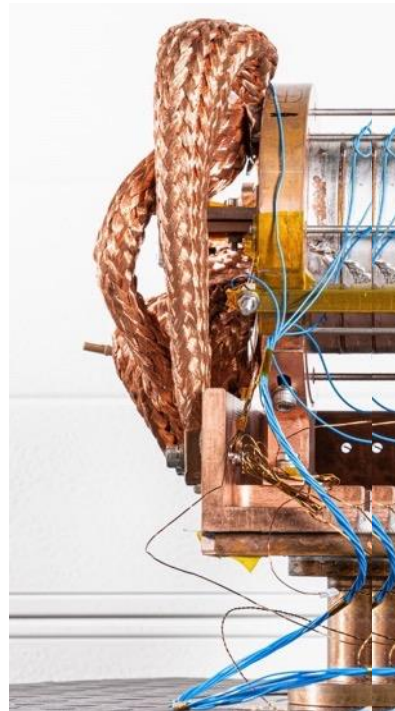
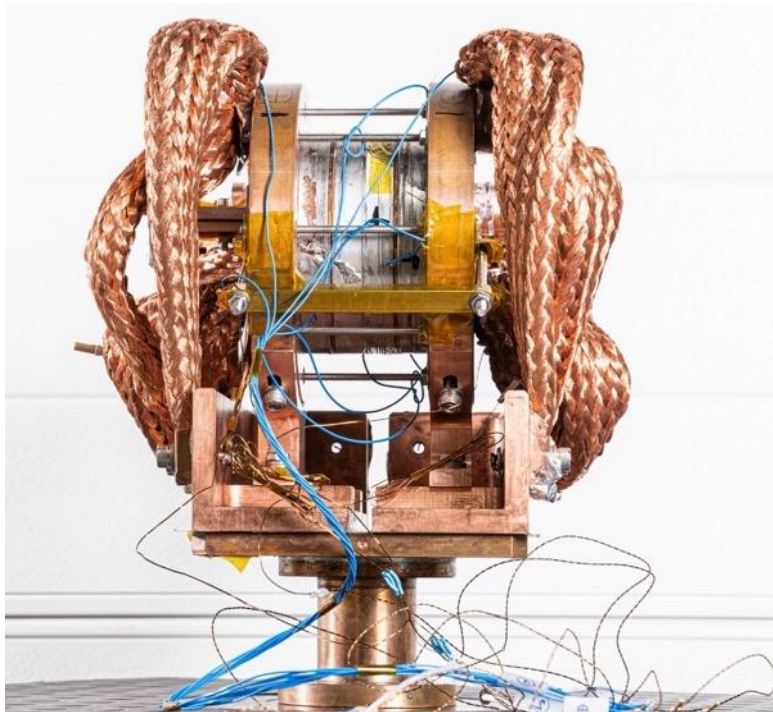

10 mm

R'Equip RIXS Manipulator Solenoid

- Proposed upgrade of the manipulator used in the RIXS beamline at SLS for soft X-ray scattering experiments.
- Supply a high magnetic field (up to 6 T) on the target.

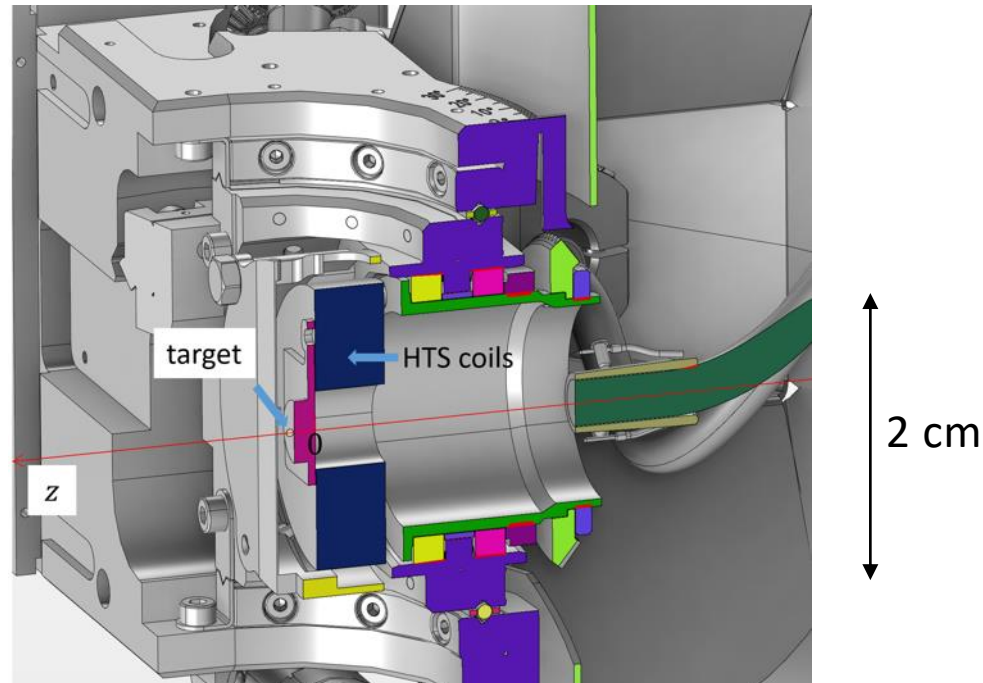

Other Technology Development with Potential for Synergies

- HTS low-loss cables.
 - Low-loss powering.
 - Compact protection.
 - Efficient thermal design.
 - Compact magnets.
-
- Room-plug standalone magnet systems with cold or warm bore for lab research.

- An ambitious SC magnet R&D program has been set up within CHART at PSI and in other national labs (CEA, CIEMAT, INFN) and at CERN.
- These are exciting times to work on SC accelerator magnets.
 - LTS magnets will see innovative technological solutions in the coming years to reach performance, robustness, and cost targets.
 - The HTS revolution is becoming real.
 - We are researching the building blocks of HTS accelerator magnet technology.
 - Challenges are real and should not be underestimated.
 - Momentum is building and ideas abound.
- Collaboration, coordination, and communication will be the key to an innovative and ultimately successful European R&D network that creates technology to enables the HEP adventures of the future.